



Product Selector

ADHESIVES AND SEALANTS





TECHNOLOGY
Center of Excellence



For over 125 years, Bostik has been a global leader in industrial adhesives and sealants.

With strong collaborative partnerships and alliances, we are a fully-owned subsidiary of Arkema and have a presence in 40 countries.

Bostik's extensive technical expertise and history of innovation enable our company to successfully address the ever-changing needs of our customers and anticipate future needs to come. We have three corporate R&D laboratories and 11 research centers worldwide.

Bostik's advanced technologies include hot melt adhesives such as **butyls, EVAs, polyesters, polyamides, polyolefins, styrenic block copolymers** and **polyurethanes** as well as some **solvent** and **water-based** versions of these chemistries. Our company also has capability in reactive adhesives including polyurethanes and silane modified polymers. Bostik designs smart adhesives to be fast, high-performing and safe, saving customers time and money while improving their manufacturing processes. Furthermore, our solutions address today's growing economical and environmental concerns.

Our range of capabilities enables us

to successfully serve several diverse industrial markets. These include **aerospace, assembly, automotive, building components, flexible and rigid packaging, general transportation and tape and label.**

For more information on our types of adhesives and sealants and the technologies behind them, please review this Product Selector.

This Product Selector was designed as a guide for our customers to assist them in choosing the best adhesive or sealant for their application. It helps guide customers through our core formulations and assist with selecting the right technology across Bostik's vast product lines.

While this guide is fairly representative of the depth of products Bostik can provide, it is not a complete list. It will help you better understand the range of our technology and products, but we encourage you to use it as a reference, and reach out to a Bostik team member for more information. We have the technical capability to help guide you to the product you need. Call **800-7-BOSTIK** with any questions.

Butyl Adhesives and Sealants

Coming Soon 7

Ethylene Vinyl Acetate Adhesives

Coming Soon 9

Film Adhesives

What are Film Adhesives?	12	Film Adhesives Selector Tool	16
Choosing the Right Film Adhesive	13	Film Adhesives Substrate Compatibility Guide	17
Benefits of Film Adhesives	14	Film Adhesives Product Table	18
Featured Film Adhesives	14		

Polyamide Adhesives

What are Polyamide Adhesives?	22	Featured Polyamide Adhesives	24
Choosing the Right Polyamide Adhesive	23	Polyamide Adhesives Selector Tool	26
Benefits of Polyamide Adhesives	24	Polyamide Adhesives Product Table	27

Polyester Adhesives

What are Polyester Adhesives?	30	Conventional Polyester Hot Melt Adhesives Product Table	35
Choosing the Right Polyester Adhesive	31	Benefits of Vitel® Polyester Hot Melt Adhesives	36
Benefits of Conventional Polyester Hot Melt Adhesives	32	Featured Vitel Polyester Adhesives	36
Featured Conventional Polyester Adhesives	32	Vitel Polyester Adhesives Selector Tool	38
Conventional Polyester Selector Tool	34	Vitel Resins Product Table	39

Polyolefin Adhesives

Coming Soon 41

Polyurethane Adhesives and Sealants

What are Polyurethane Adhesives?	44	Featured Polyurethane Adhesives	46
Choosing the Right Polyurethane Adhesive	45	Polyurethane Adhesives Selector Tool	48
Benefits of Polyurethane Adhesives	46	Polyurethane Adhesives Product Table	49

Silane Modified Polymer Sealants

Coming Soon	51
-------------------	----

Solvent-Based Adhesives

Coming Soon	53
-------------------	----

Styrenic Block Copolymer Adhesives

What are SBC Adhesives?	56	Benefits of Hot Applied SBC Adhesives	62
Choosing the Right SBC Adhesive	57	Featured Hot Applied SBC Adhesives	62
Benefits of Pressure Sensitive SBC Adhesives	58	Hot Applied SBC Adhesives Selector Tool	64
Featured Pressure Sensitive SBC Adhesives	58	Hot Applied SBC Adhesives Substrate Compatibility Guide	65
Pressure Sensitive SBC Adhesives Selector Tool	60	Hot Applied SBC Adhesives Product Table	66
Pressure Sensitive SBC Adhesives Product Table	61		

Water-Based Adhesives

Coming Soon	67
-------------------	----

Web Adhesives

What are Web Adhesives?	72	Web Adhesives Selector Tool	76
Choosing the Right Web Adhesive	73	Web Adhesives Substrate Guide	77
Benefits of Web Adhesives	74	Web Adhesives Product Table	78
Featured Web Adhesives	74		

IMPORTANT – PLEASE READ BEFORE USING BOSTIK'S PRODUCT SELECTOR

Terms & Conditions

Bostik, Inc. ("Bostik") specifies the conditions wherein technical information and recommendations contained in its documentations may be used. Bostik offers this Product Selector for descriptive and informational use only. The Product Selector is not a substitute for expert or professional advice.

The statements, technical information and recommendations contained herein are believed to be accurate as of the date hereof. The Product Selector relies upon your knowledge and input, and as such, its results are based solely upon the information you provide and the choices that you make. Since the conditions and methods of use of the products and the information referred to herein are beyond our control, Bostik expressly disclaims any and all liability and damages that may arise from any use of the Product Selector, the products, the results therefrom, or reliance on the information contain herein, and you hereby agree to waive any and all claims against Bostik relating in anyway thereto.

The Product Selector is one of several tools that may be used to help you find the product best suited for your needs. It is used at your own risk, and by using it, you are knowingly accepting and assuming any and all risks associated with its use, recommendations, output and your selections. You are responsible to test the suitability of any product in advance for any intended use. Bostik does not guarantee the reliability, completeness, use, or function of the Product Selector or any recommendations arising therefrom. The data and information contained in the Product Selector is provided 'AS IS'.

The information provided herein relates only to the specific products designated and may not be applicable when such products are used in combination with other materials or in any process. **Bostik encourages you to always read and understand (1) the Technical Data Sheet ("TDS") and (2) the Safety Data Sheet ("SDS") for all products before use.** The SDS contains the necessary information related to prevention and safety related to the use of a product. In addition to information about the product's properties, it provides recommendations about storage, conditions of use, handling, transportation of the product (hazard level, packaging groups), elimination or destruction and the procedure in the event of an accident. The Safety Data Sheets for our products can be found at <http://www.bostik.com/us/tools-and-training/bostik-sds/>. Also, Technical Data Sheets for our products can be found at <http://www.bostik.com/us/tools-and-training/bostik-tds/>. You are welcome and encouraged to contact your customer service representative to discuss your specific requirements and to determine what product is appropriate for you and your applications.

NO WARRANTY OF FITNESS FOR ANY PARTICULAR PURPOSE OR WARRANTY OF MERCHANTABILITY, EXPRESSED OR IMPLIED, IS MADE CONCERNING THE PRODUCTS DESCRIBED OR THE INFORMATION PROVIDED HEREIN, AND SUCH WARRANTIES ARE HEREBY DISCLAIMED. Additionally, Bostik disclaims any liability for direct, incidental, consequential, or special damages to the maximum extent allowed by law. (Some states do not allow the exclusion or limitation of incidental or consequential damages, so the above limitations may not apply to you.)

Nothing contained herein constitutes a license to practice under any patent, and it should not be construed as an inducement to infringe any patent. You are advised to take appropriate steps to be sure that any proposed use of the products will not result in patent infringement.

Medical Device Disclaimer

Bostik has implemented a policy regarding the use of Bostik products in Medical Devices applications that are in contact with the body or circulating bodily fluids. Bostik strictly prohibits the use of any Bostik products in Medical Device applications that are implanted in the body or in contact with bodily fluids or tissues for greater than 30 days. The Bostik trademarks and the Bostik name shall not be used in conjunction with customers' medical devices, including without limitation, permanent or temporary implantable devices, and customers shall not represent to anyone else, that Bostik allows, endorses or permits the use of Bostik products in such medical devices.

It is the sole responsibility of the manufacturer of the medical device to determine the suitability (including biocompatibility) of all raw materials, products and components, including any Bostik products, in order to ensure that the final end-use product is safe for its end use; performs or functions as intended; and complies with all applicable legal and regulatory requirements (FDA or other national drug agencies). It is the sole responsibility of the manufacturer of the medical device to conduct all necessary tests and inspections and to evaluate the medical device under actual end-use requirements and to adequately advise and warn purchasers, users, and/or learned intermediaries (such as physicians) of pertinent risks and fulfill any post market surveillance obligations. Any decision regarding the appropriateness of using a particular Bostik material or product in a particular medical device should be based on the judgment of the manufacturer, seller, the competent authority, and the treating physician.

Acceptance of Terms & Conditions

By using this Product Selector, you are hereby consenting and agreeing to the above terms and conditions of use, and you agree to waive certain rights as set forth herein.

(Revised May 3, 2016)

BUTYL ADHESIVES AND SEALANTS

Coming Soon



BUTYL ADHESIVES AND SEALANTS

Coming Soon





ETHYLENE VINYL ACETATE ADHESIVES

Coming Soon



ETHYLENE VINYL ACETATE ADHESIVES

Coming Soon

ETHYLENE VINYL ACETATE



FILM ADHESIVES

Aerospace Interior Assembly | Aircraft Decorative
Laminate Construction and Attachment | Assembly of
Electronics | Decal Assembly | Fabric to Foils, Films and
Foam Bonding | Mounting Adhesive | Textile Bonding
Rail Interior Assembly | Vinyl Laminate Bonding

Film Adhesives

Bostik's film adhesives are high-performance, solvent-free bonding agents supplied in convenient, easy-to-use forms. As a result of their unique characteristics, Bostik's film adhesives offer **functional and cost benefits to manufacturers in many industries.**

What are Film Adhesives?

In their simplest form, film adhesives consist of a thin layer of adhesive supported on a peelable backing. They can be widely used on products ranging from aircrafts and automobiles to toys, appliances, clothing and electronic instruments. Their versatility frees designers from many of the usual constraints and often provides a convenient, economical solution to otherwise difficult or costly joining problems.

Bostik's film adhesives are typically solvent-cast adhesives that form a thin flexible layer, which can be heat activated or pressure sensitive for various

applications. Film thicknesses range from one to five mils. The standard width is 60 inches; however, custom widths are available from 30 to 61 inches. These films help control consistency in the application usage variance to give repeatable performance characteristics.

Each film adhesive offers unique performance characteristics and serves a different use. It is critical to understand an application's processing and mechanical needs in order to determine which type of film adhesive is best suited.

Bostik offers three different types of film adhesives:

Thermoset Adhesives

- Require heat and pressure to adhere the film to the substrate and form a strong cross-linked adhesive network that is not reversible
- Are cross-linking, which enables the bond line to resist higher temperatures than the non-cross-linked system

Thermoplastic Adhesives

- Require heat to adhere to the substrate, but form a reversible bond that can be deactivated with heat
- Depending on the temperature sensitivity of the substrates being bonded, Bostik offers adhesives with a range of melting and curing conditions.

Pressure Sensitive Adhesives (PSA)

- Do not require heat to form a bond; they can simply be exposed to a small amount of pressure to adhere
- Can be formulated as cross-linking adhesives to enhance end use performance





Choosing the Right Film Adhesive

Film Thickness

- The film manufacturing process has the ability to make a range of film thicknesses, which allows users the capability to more easily customize the bond strength of their application.
- The ideal film thickness will depend on the specific substrates, processing conditions and film type being used for an application.

Flame Retardancy

- These film adhesives are an excellent way to impart additional flame retardancy into a layered system.
- Just like the non-flame retardant film adhesives, both the thickness and width of the film can be varied to meet custom needs.

Carrier

- The other factor to consider in selecting a film adhesive is the carrier(s) used to supply the adhesive.
- Depending on the way the adhesive will be processed, one film construction may be more desirable than another. Bostik offers three different construction forms.

Single Release Liner

- This film construction is an unsupported film adhesive that is simply an adhesive on a paper release liner.
- This type of construction is denoted in the film name by starting with "F10".

Two-sided Release Liner

- This film construction is an unsupported film adhesive on paper and polyethylene release liners. It provides a mirrorlike bonding surface on one side of the adhesive, which can minimize adhesive show-through in the application.
- This construction is particularly desirable for die-cutting operations. It is denoted in the film name as "F14".

Supported

- This film construction is a fiberglass-supported film adhesive without a liner. The adhesive is applied directly to the fiberglass.
- This construction is denoted in the film name as "F15".

Benefits of Film Adhesives

Bostik's film adhesives are thin films that are heat or pressure activated and can vary in thickness and width. These products offer

several advantages over other bulk adhesives and alternative bonding options.

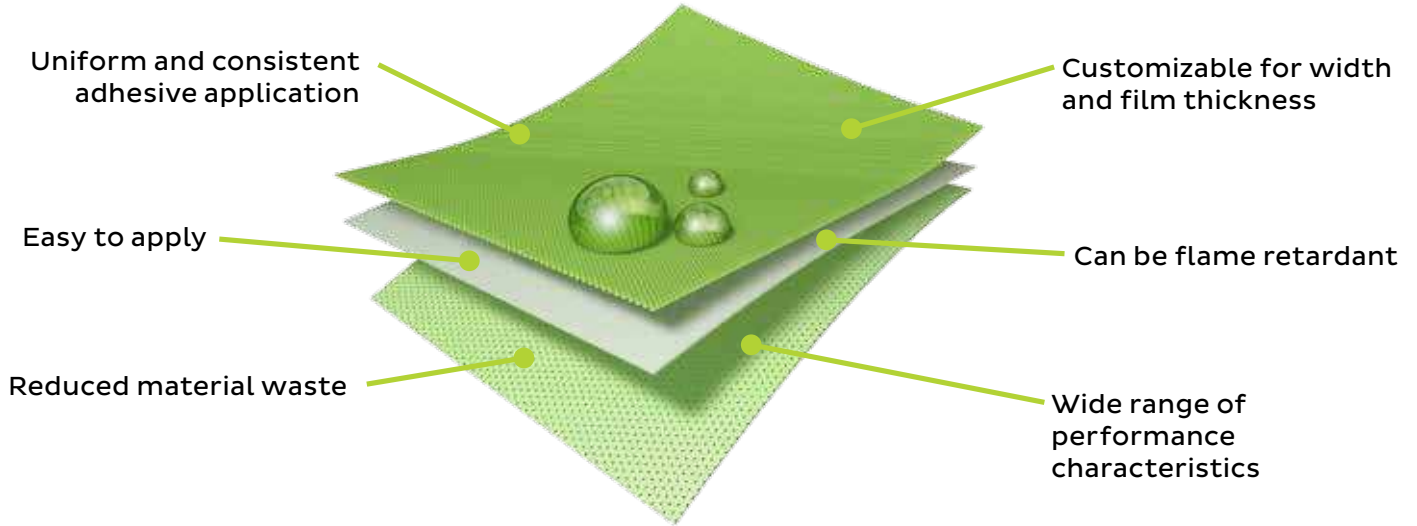

Featured Film Adhesives

F10-316 Polyester Thermoset Film Adhesive

Key Features

- Low temperature activation
- Fast curing
- Good water resistance

Bostik's film adhesive F10-316 is a fast curing, thermoset film based on linear saturated copolyester resins. It is designed to have excellent adhesion to fabrics and foams while imparting excellent wash resistant properties when cured. The F10-316 film has a fast set time and is softer with improved flow properties compared to other Bostik film adhesives.



TYPICAL PHYSICAL PROPERTIES

Description	Results
Appearance	White to Light Yellow Film
Dry film thickness	2 mils (0.005cm)
Dry film weight (2 mil film)	56 g/yd ² (67g/m ²)
Liner Properties	silicone-coated 60# bleached kraft
Release from liner (before heat is applied)	80g/inch (max.)
Volatiles	< 3.0%

F10-337L

Flame Retardant Thermoplastic Film Adhesive

Key Features

- Excellent flame retardant properties
- Low temperature activation
- Brown colored film

F10-337L is a non-halogenated, flame retardant, thermoplastic film adhesive based on a linear saturated copolyester resin. It is designed to have excellent adhesion to fabrics and foams while imparting excellent flame resistant properties.



TYPICAL PHYSICAL PROPERTIES

Description	Results
Color	Brown
Release Liner	60# silicone-coated, super calendared, brown Kraft
Dry Film Thickness	2.5 mils (0.006 cm)
Dry Film Weight (2.5 mil film)	87.8 g/yd ² (105 g/m ²)
% Volatiles	<3.6%

AVAILABILITY

Properties	Values
Roll Width (typical)	57 inches (145 cm)
Roll Length (typical)	500 linear yards (457 m)
Core I.D.	3 inches (7.6 cm)

F14-588

Flame Retardant Pressure Sensitive Film Adhesive

Key Features

- Excellent peel and shear strength
- Low OSU heat release and smoke generation
- Meets BMS 5-91 TYPE IV product specification

F14-588 is a flame retardant, acrylic, film adhesive. The primary application for F14-588 is the bonding of flexible PVF and vinyl materials for the interior of commercial aircraft and trains. This film adhesive offers excellent shear and heat resistance while maintaining low OSU heat release and smoke generation. F14-588 is the non-decabromodiphenyl ether offset to F14-576.



TYPICAL PHYSICAL PROPERTIES

Description	Results
Film Weight	60 and 90 g/m ²
% Volatiles	< 2.5%
Peel from 6 mil Paper Liner	12 g/in (4.7 g/cm)
Peel from 4 mil LDPE Liner	40 g/in (16 g/cm)

AVAILABILITY

Film Thickness	2 and 3 mils (51 and 76 microns)
Width	55 to 61 in (140 to 155 cm)
Length	100 to 220 ly (91-201 m)
I.D. Core Size	3 in (7.6 cm)

Selecting the Right Film Adhesive

Non-Flame Retardant

Heat Resistance

< 250°F

F10-316

> 250°F

F10-250

Flame Retardant

Curing System

No

Yes

Pressure Sensitive

No

Yes

Good Green Strength During Processing

No

Yes

F10-337L

FPA110-1FR

F14-588

F10-651B



Film Substrate Compatibility

Product		Substrate Compatibility														
		Fabric	Leather	Urethane Foam	Wood	Metals	Aluminum	Fiberglass	Rubber	Treated PP	PVC	ABS	PVDF	Tedlar	PEI	PEEK
Non-Flame Retardant Thermoset Films	F10-250	●	●	●	●	●	●	●	●	●	●	●	●	●	●	●
	F10-300	●	●	●	●	●	●	●	●	●	●	●	●	●	●	●
	F10-305	●	●	●	●	●	●	●	●	●	●	●	●	●	●	●
	F10-316	●	●	●	●	●	●	●	●	●	●	●	●	●	●	●
Flame Retardant Thermoplastic Films	F10-337L	●	●	●	●	●	●	●	●	●	●	●	●	●	●	●
	FPA110-1FR	●	●	●	●	●	●	●	●	●	●	●	●	●	●	●
Flame Retardant Pressure Sensitive Films	F14-552	●	●	●	●	●	●	●	●	●	●	●	●	●	●	●
	F14-554	●	●	●	●	●	●	●	●	●	●	●	●	●	●	●
	F14-588	●	●	●	●	●	●	●	●	●	●	●	●	●	●	●
Flame Retardant Thermoset Films	F10-651B	●	●	●	●	●	●	●	●	●	●	●	●	●	●	●
	F15-789	●	●	●	●	●	●	●	●	●	●	●	●	●	●	●

The chart above provides typical substrates with which Bostik's film adhesives have been used, but is not a guarantee of suitability. Bostik recommends evaluating the performance of a film adhesive in individual applications to ensure performance requirements are achieved.

Film Adhesive Products

Film Type	Product	Base Polymer Type	Application Temperature for Bonding (°F)	Suggested Curing Conditions	Adhesive Weight for a 3 mil film (g/m ²)	Temperature Resistance (°C)	Water Resistance	Solvent Resistance	Product Benefits
Non-Flame Retardant Thermoset Films	F10-250	Nitrile Phenolic	220-250	3-10 minutes @ 360°F	79	400	Good	Excellent	Excellent heat, fuel & oil resistance
	F10-300	Polyester	230-250	5 minutes @ 340°F	94	250	Excellent	Good	Very flexible, launderable
	F10-305	Polyester	230-250	6 minutes @ 340°F	94	250	Excellent	Good	Very flexible, launderable
	F10-316	Polyester	200-250	<1 minute @ 350°F	100	150	Excellent	Good	Very flexible, launderable, improved processing, faster cure rate than F10-300
Flame Retardant Thermoplastic Films	F10-337L	Polyester	194	Does not cure	124	200	Good	Good	Low activation temperature, passes UL 94 V0 standard, halogen & antimony-free
	FPA110-1FR	Polyamide	220-235	Does not cure	95	200	Good	Good	Heat resistance to 200°F, excellent flame retardant properties
Flame Retardant Pressure Sensitive Films	F14-552	Acrylic	Room temperature	Does not cure	97	-20 to 250	Good	Good	Good peel & shear strength, good heat resistance
	F14-554	Acrylic	Room temperature	Does not cure	94	-20 to 180	Good	Good	Excellent peel & shear properties, very low smoke generation, halogen-free
	F14-588	Acrylic	Room temperature	Does not cure	94	-20 to 180	Good	Good	Very high peel, shear & tack, low OSU heat release & smoke generation
Flame Retardant Thermoset Films	F10-651B	Phenoxy Urethane	250-275	10 minutes @ 320°F, 100 psi	132	400	Excellent	Excellent	Cured film exhibits excellent solvent & heat resistance
	F15-789	Phenoxy Urethane	250-275	10 minutes @ 320°F, 100 psi	130**	400	Excellent	Excellent	Excellent durability, low OSU heat release, coated on fiberglass

** Does not account for fiberglass weight.



James

Bostik
adhesives and sealants



HOT MELT POLYAMIDE ADHESIVES

Automotive Interiors | Cabinet Assembly | Filter Assembly
General Product Assembly | Textile Laminations | Wood Bonding

POLYAMIDE



Hot Melt Polyamide Adhesives

Bostik's hot melt polyamide adhesives are **100% non-volatile thermoplastic adhesives**. Supplied in pellet form and solid at room temperature, these adhesives melt when heat is applied and quickly set to **provide a bond with high heat resistance and good chemical resistance**.

What are Hot Melt Polyamide Adhesives?

Bostik's hot melt polyamides are one type of our high-performance, thermoplastic resins. These adhesives offer characteristic properties necessary in demanding performance environments: chemical and grease resistance, resistance to plasticizer migration and high temperature performance.

Bostik supplies dimer acid based, hot melt polyamide adhesives from a melt tank in pellet form for applications in the filter, automotive and assembly markets.

For some applications, a bulk hot melt might not be the right adhesive choice. Bostik offers nylon (polyamide) web adhesives with slight differences in chemistry that have similar features and benefits to the hot melt polyamide products. Refer to the Web Adhesives section for more information.





Choosing the Right Hot Melt Polyamide Adhesive

Understand the required temperature performance

The temperature requirements of an application are a primary concern when choosing a polyamide.

- Bostik's hot melt polyamide adhesives offer high temperature performance (>150°C).
- Some applications require the ability to maintain a bond at low temperatures.
- Adhesive performance should be verified at both extremes.

Consider process requirements

Bostik's hot melt polyamide adhesives have a range of open times (20-60 sec). Process parameters can guide selection of the right product.

Determine the environmental conditions

Along with temperature, environmental elements should also be considered. Polyamides are well known for addressing challenging environmental conditions presented by:

- Chemical and grease resistance
- Presence of plasticizer in substrates or exposure to plasticizing agents

Consider substrate compatibility

The chemical nature of Bostik's polyamides offers good specific adhesion compared to other hot melt adhesives. Bostik's polyamide adhesives are well-suited for a variety of substrates:

- Wood
- Leather
- Fabric
- Paper
- Many plastics
- Heated metal

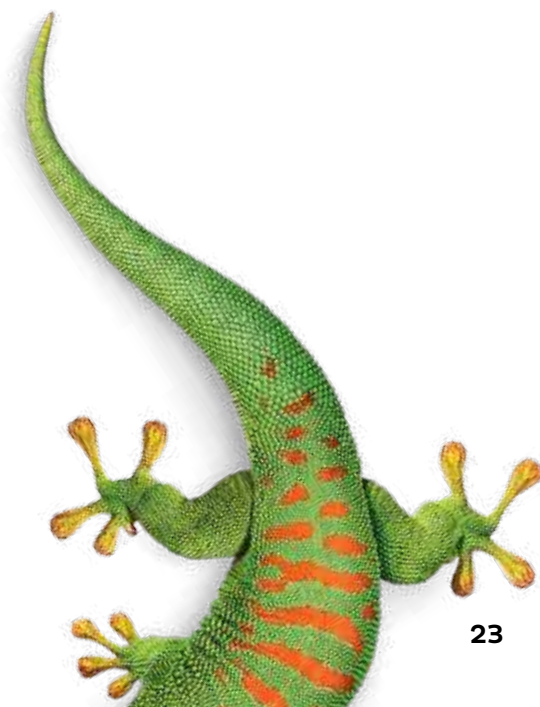

Benefits of Hot Melt Polyamide Adhesives

Bostik's hot melt polyamide adhesives offer a range of benefits:

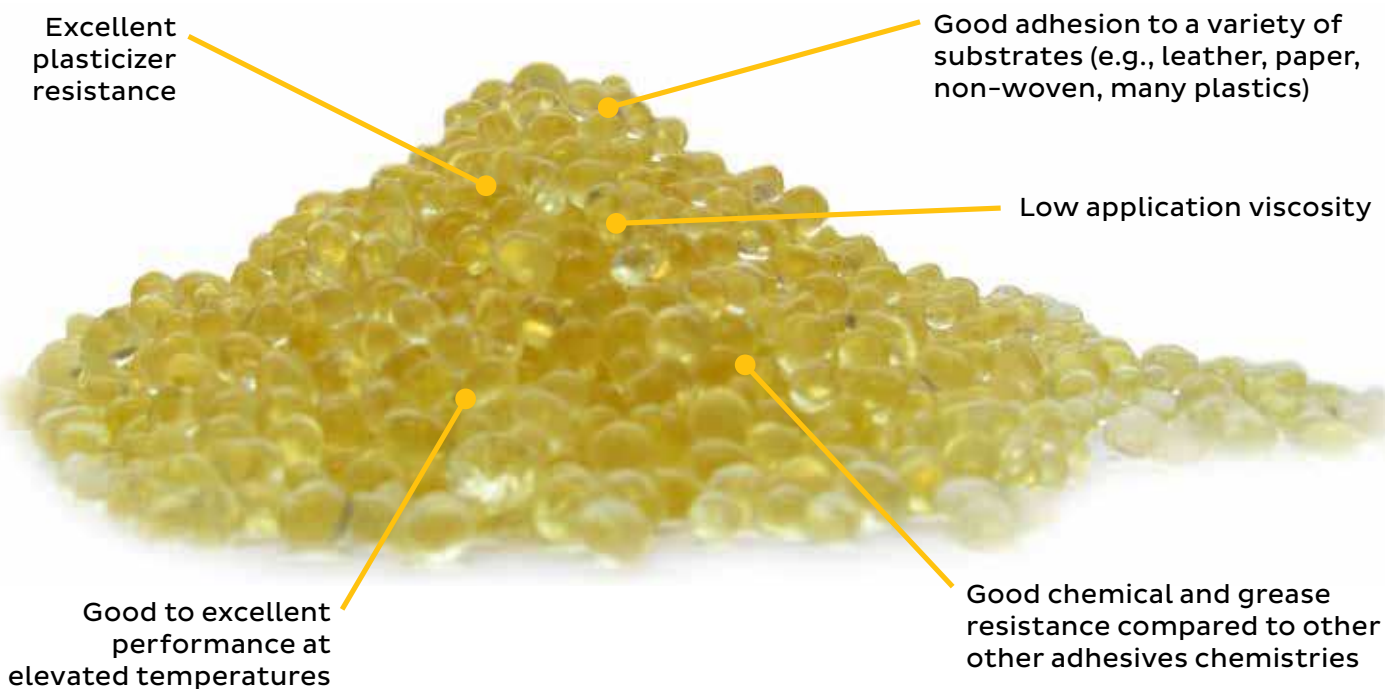

Featured Hot Melt Polyamide Adhesives

HM4229

Hot Melt Dimer Acid Polyamide Adhesive

Key Features

- Excellent plasticizer resistance
- Long open time
- Good temperature resistance

Bostik's HM4229 is thermoplastic, dimer acid polyamide supplied in a pellet form. This product has been developed to bond to a variety of substrates including wood, metal and many plastics including plasticized PVC. HM4229 offers the combined benefit of low application viscosity for ease of application and a good balance of high and low temperature properties.



TYPICAL PHYSICAL PROPERTIES

Description	Results
Appearance	Light Amber Pellets
Density	1.01 g/cc
Softening Point (Ball & Ring)	144°C
Thermosel Viscosity	4,000 cP @ 200°C
Tensile at Break	790 psi (5,400 kN/m ²)
Elongation at Break	350%
Shore D Hardness	30
Relative Open Time @ 218°C	50-60 seconds

HM4278

Hot Melt Dimer Acid Polyamide Adhesive

Key Features

- High temperature resistance
- Fast set
- Good chemical and grease resistance

Bostik's HM4278 is a high-performance, dimer acid polyamide adhesive designed for filter applications. This specialty adhesive offers the combined benefit of a low viscosity for applications requiring high outputs and a good balance of high and low temperature properties.



TYPICAL PHYSICAL PROPERTIES

Description	Results
Appearance	Amber Pellets
Density	1.0 g/cc
Softening Point (Ball & Ring)	363°F (184°C)
Thermosel Viscosity	5,000 cP @ 204°C
Tensile at Break	1,655 psi (11,410 kN/m ²)
Elongation at Break	240%
Shore D Hardness	43
Relative Open Time @ 218°C	20-30 seconds

HM4289

Hot Melt Dimer Acid Polyamide Adhesive

Key Features

- High temperature resistance
- Moderate open time
- Excellent plasticizer migration resistance

Bostik's HM4289 is a specially developed thermoplastic, dimer acid, polyamide adhesive in pellet form. This product has been developed to bond to a variety of substrates including wood, engineered papers, non-wovens for the filter market and other materials used in automotive applications. HM4289 offers the benefits of low viscosity for applications requiring high outputs and a good balance high and low temperature properties.



TYPICAL PHYSICAL PROPERTIES

Description	Results
Appearance	Amber Pellets
Density	1.0 g/cc
Softening Point (Ball & Ring)	170°C
Thermosel Viscosity	5,250 cP @ 200°C
Tensile at Break	1,740 psi (12,000 kN/m ²)
Elongation at Break	290%
Shore D Hardness	48
Relative Open Time @ 218°C	20-30 seconds

Selecting the Right Hot Melt Polyamide Adhesive

Low Temperature Performance

< 150°C

High Temperature Performance

> 150°C

Processing Speed (Set Time)

Long
50-60 seconds

Moderate
20-30 seconds

Processing Speed (Set Time)

Moderate
20-30 seconds

Short
15-25 seconds

HM4229*

HM4231*

Flexibility

Moderate

Good

HM4278+

HM4289*

HM4279LV+



* Good resistance to plasticizer migration
+ Good chemical and/or grease resistance

Hot Melt Polyamide Adhesive Products

Product	Appearance	Softening Point (°C)	Tensile (psi), 25°C	Elongation (%), 25°C	Open Time (s)†	Viscosity (cp)‡	Shore D Hardness	Application Temperature (°C)	Product Benefits
HM4229	Light amber pellet	144	790	350	50-60	4000	30	180-204	Good temperature resistance, excellent plasticizer resistance, long open time
HM4231	Light amber pellet	144	875	550	20-30	3750	30	191-218	Good balance of strength & elongation, excellent plasticizer resistance
HM4276	Amber pellet	180	1850	235	20-30	5250	39	210-232	High temperature resistance, good chemical resistance, good flexibility
HM4277	Amber pellet	185	1865	270	20-30	5000	46	200-225	High temperature resistance, good chemical resistance, moderate flexibility
HM4278	Amber pellet	184	1655	240	15-25	5000	43	200-225	High temperature resistance, fast set, good chemical & grease resistance
HM4279LV	Amber pellet	173	2590	245	20-30	4750	49	191-218	High temperature resistance, high tensile strength, good chemical resistance
HM4289	Amber pellet	170	1740	290	20-30	5250	48	196-207	High temperature resistance, excellent plasticizer resistance

† 425°F, 1/8 - 3/16" bead

‡ RVT: spindle 27, 20 rpm, ~200°C





POLYESTER ADHESIVES

**Electrical Components | Filter Assembly | Food and Medical Packaging | General Industrial Assembly | Heat Seal Coatings
Ink Binders | Label Adhesives | Laminating Adhesives
Optically Clear Coatings | Primers | Textile Laminations**



Polyester Adhesives

Bostik offers a **versatile line of high performance adhesives** based on **polyester polymers**. These polymers enable adhesives to be developed that **offer specific physical properties** and performance characteristics.

What are Polyester Adhesives?

Bostik's polyester adhesives are 100% non-volatile, thermoplastic adhesives that are solid at room temperature, liquefy upon heating and re-solidify with cooling. They form nearly instantaneous bonds, can improve product appearance and save on product weight. Since Bostik designs and manufactures our own polyester polymers, we are able to supply polyester hot melt adhesives and resins in a variety of forms for every type of application process.

Bostik offers two categories of polyester adhesives in our product line: conventional hot melt adhesives and Vitel resins. The conventional hot melt adhesives are similar to other hot melt adhesives that are designed to be used in the form in which they are sold. The same design applies to Vitel® resins. However, Vitel resins also are designed to be easily processed further and blended to a more customized adhesive or coating material.

Conventional Hot Melt adhesives

- Adhesive grade polyesters for assembly applications
- Available in pellets and granules
- Can be applied via slot-die, bead application, spray coating or extrusion
- Broad range of heat resistance temperatures from 225° to 350°F

Vitel Resins

- Amorphous, semi-crystalline adhesives and compounding resins
- Available in pellets, granules and thin slabs
- Extrusion grade and soluble grades available
- Broad range of chemical resistance and hydroxyl functionality available



Choosing the Right Polyester Adhesive

Consider the application equipment or process

Determining the type of equipment or process that will be used to apply the adhesive to the substrate is a critical step in identifying the best polyester adhesive for any application.

Conventional hot melt reservoir application

If using the product as an adhesive in conventional hot melt application equipment, then factors to consider are those common to hot melt applications:

- Substrate affinity
- Application and use temperature requirements
- Other relevant physical properties for the application

Bostik offers adhesives with varying levels of temperature resistances and flexibility to meet application requirements.

Extruded application

If the product is going to be extruded, then the Vitel 1000 series extrusion resins should be considered. The Vitel 1000 series are:

- High molecular weight extrusion resins
- Offered in amorphous, semi-crystalline grades
- Have high cohesive strength and tensile modulus
- Exceptional at bonding to PET and PVC.

The desired adhesion and activation temperature will determine the best combination of resins to use.

Coating application

When using the polyesters to create a coating, the Vitel 2000 series coating resins are best suited. Characteristics of the Vitel 2000 series include:

- Solution-applied, high molecular weight amorphous thermoplastic resins
- High tensile strength and low elongation
- High abrasion resistance
- Clarity and great UV stability

The desired application temperature and chemical resistance properties help determine which resin to select.

Laminating application

If the application requires a solvated adhesive for a lamination application, the Vitel 3000 and 7000 series laminating resins would be the products to consider. Characteristics of the Vitel 3000 and 7000 series include:

- Solution-applied, high molecular, weight resins amorphous and semi-crystalline resins
- Good UV stability
- Excellent flexibility
- Excellent tensile strength and elongation

They have glass transition temperatures below room temperature and can have excellent chemical resistance and cross-linking ability.

Benefits of Conventional Polyester Hot Melt Adhesives

Bostik's conventional polyester hot melt adhesives offer a range of benefits:

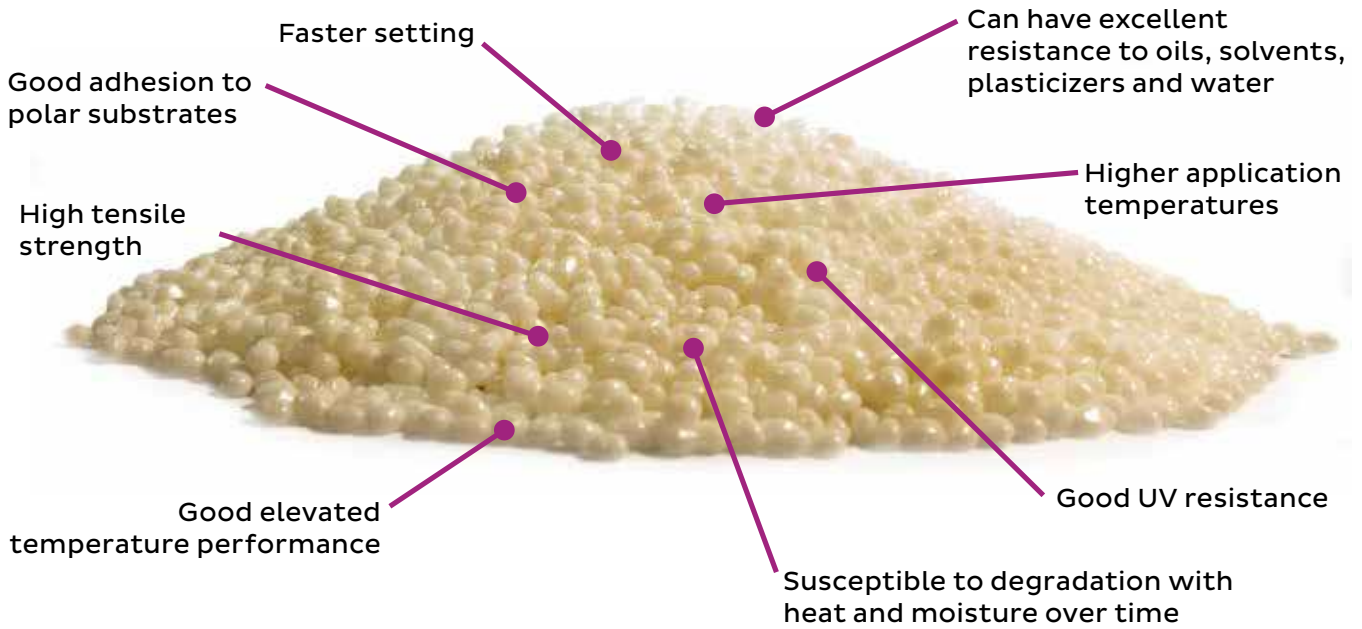

Featured Conventional Polyester Hot Melt Adhesives

HM4199MV

Polyester Hot Melt Adhesive

Key Features

- High temperature resistance
- Low application viscosity
- Fast set time

HM4199MV is a high-performance, polyester hot melt adhesive designed to bond a variety of fabrics, urethane foam and vinyl. Bostik's HM4199MV exhibits excellent high temperature resistance, superior resistance to plasticizer migration and resistance to water.



TYPICAL PHYSICAL PROPERTIES

Description	Results
Appearance	Off-White Pellets
Tensile Strength at 25°C	699 psi
Elongation at 25°C	50%
Softening Point (Ball & Ring), ASTM E28	177°C
DSC Melt Point	170°C
Melt Viscosity (Brookfield thermosel, spindle #27)	265-350°F (130-177°C)
Density	1.28 g/cm ³
Heat Resistance (1kg/in ² load, oven temp. increased 5°C/30 min.)	170°C

HM4118NSN

Polyester Hot Melt Adhesive

Key Features

- Excellent wash resistance and very good dry clean resistance
- Medium open time
- Tin-free formula

HM4118NSN is a high-performance, hot melt polyester adhesive. A versatile product with outstanding high and low temperature resistance, this adhesive is used in a wide variety of applications, bonding substrates such as paper products, leather, woven and nonwoven fabrics.

HM4118NSN has excellent resistance to both laundering and dry cleaning. This adhesive is produced without the use of tin as a catalyst to comply with metal restrictions in various markets.



TYPICAL PHYSICAL PROPERTIES

Description	Results
Appearance	Off-white
Softening Point (Ball & Ring)	284°F (140°C)
DSC Melt Point	261°F (127°C)
Melt Viscosity	170,000 cP @ 419°F (215°C)
Melt Flow Index (175°C/2.16 kg)	17 g/10 min
Density	1.24 g/cm ³
Tensile Strength	5,360 psi (37,000 kN/m ²)
Elongation at Break	520%
Relative Open Time (392°F/200°C)	Medium
SAFT (1000 g/in ² 5°C/min)	275°F (135°C)

HM4157D

Polyester Hot Melt Adhesive

Key Features

- Good wash resistance
- Low application temperature
- Moderate heat resistance

Bostik's HM4157D is a high-performance, polyester hot melt adhesive. Supplied in pellet form, HM4157D was designed to bond a variety of fabrics. This resin offers an adhesive option with a lower application temperature, which makes it well-suited for applications where lower temperature is preferred. Potential applications for HM4157D include textiles and apparel as well as general assembly.



TYPICAL PHYSICAL PROPERTIES

Description	Results
Appearance	White Pellets
Softening Point (Ball & Ring)	117°C
Melt Viscosity	60,000 cP @ 215°C
Melt Flow Index (160°C, 2160 grams, dried)	32.5 g/10 min
Density	1.25 g/cm ³

Selecting the Right Polyester Hot Melt Adhesive

Melt Tank Processing

Extrusion Processing

Heat Resistance

Heat Resistance

Moderate
< 250°F

Good
< 285°F

Excellent
< 350°F

Moderate
< 250°F

Good
< 285°F

Application Temperature

HM7116

Flexibility

HM4105

HM4118NSN

Low
300°F

Moderate
375°F

Low

Good

HM4157D

HM4199LV

HM4183

HM4156LV



Conventional Polyester Hot Melt Adhesive Products

Product	Form	Morphology	B&R Softening Point (°C)	Thermoset Viscosity (cp)	Tensile (psi)	Elongation (%)	SAFT (°C)	Application Temperature (°C)	Product Benefits
HM1335141	Pellets	C	133	17,000 @ 215°C	-	-	120 (500 g/in ² ,5°C/30 min)	191-218	Lower viscosity
HM4103	Pellets	C	125	42,400 @ 225°C	2290	490	110 (1 kg/in ² ,5°C/30 min)	232-246	Extended open time
HM4105	Pellets	C	120	200,000 @ 215°C	-	-	-	171-218	Fast crystallizing, high viscosity & lower melt temperature
HM4117	Pellets	C	140	150,000 @ 215°C	3,070	380	125 (1 kg/in ² ,5°C/min)	171-216	Excellent extrudability, broad melting point
HM4118	Pellets	C	140	170,000 @ 215°C	5360	520	135 (1 kg/in ² ,5°C/min)	171-216	Higher viscosity than HM4117, excellent extrudability
HM4118NSN	Pellets	C	140	170,000 @ 215°C	5360	520	135 (1 kg/in ² ,5°C/min)	171-216	Tin-free version of HM4118, excellent extrudability
HM4156LV	Pellets	C	157	18,000 @ 215°C	2700	400	137 (500 g/in ² ,5°C/30 min)	204-246	Lower viscosity, excellent heat resistance, moderate set time
HM4157D	Pellets	C	117	60,000 @ 215°C	-	-	-	149-204	Low application temperature
HM4183	Pellets	C	115	35,000 @ 215°C	-	-	105 (1 kg/in ² ,5°C/min)	191-218	Low application temperature, long open time
HM4186	Pellets	C	-	140,000 @ 180°C	-	-	-	-	Low application temperature
HM4199LV	Pellets	C	177	16,000 @ 215°C	699	50	170 (1 kg/in ² ,5°C/30 min)	204-232	Excellent heat resistance, very low viscosity, fast set time
HM4199MV	Pellets	C	177	19,000 @ 215°C	699	50	170 (1 kg/in ² ,5°C/30 min)	204-232	Excellent heat resistance, low viscosity, fast set time
HM7116	Granules	C	137	28,000 @ 215°C	3,940	500	125 (1 kg/in ² ,5°C/min)	204-232	Steam activatable, low application viscosity, moderate open time

Benefits of Vitel Polyester Hot Melt Adhesives

Bostik's Vitel polyester hot melt adhesives offer a range of benefits:



Featured Vitel Polyester Hot Melt Adhesives

V3350B

Vitel Copolyester Laminating Resin

Key Features

- Low glass transition temperature
- Good compatibility with other Vitel resins
- Good flow characteristics

Bostik's V3350B is an amorphous, linear, saturated polyester with solubility in certain common solvents (e.g., Ethyl acetate, MEK, Toluene). V3350B is a low Tg polymer that is designed to be used as part of a solvent-based, laminating adhesive. The low glass transition temperature yields highly flexible films. The Tg can be modified to meet application requirements by blending this product with other Vitel resins and can be used as a modifier in other Vitel formulations to impart flexibility and improve adhesion.



TYPICAL PHYSICAL PROPERTIES

Description	Results
Appearance	Amber Slabs
Odor / Taste	None / None
Intrinsic Viscosity	0.80 dL/g
CIELab Color	L* : 95 (min.) b* : 10 (max.)
Specific Gravity	1.22
Softening Point	257°F (125°C)
Molecular Weight (Mw)	70,000
Acid Number	0-2
Hydroxyl Number	3-6
Glass Transition, Tg (ASTM E 28-67)	61°F (16°C)

V1801

Vitel Copolyester Extrusion Resin

Key Features

- Excellent chemical resistance
- Low activation temperature
- Adheres to a wide range of cup stocks including PP, PET, PLA and PVC

V1801 is a semi-crystalline, high molecular weight, linear, saturated copolyester resin developed for lidding in food contact applications. It is also suitable for other specialty packaging applications and flexible laminates. V1801 has excellent chemical resistance, performs well at low temperatures, adheres well to low energy substrates and is UV resistant. The properties of V1801 make it well-suited for lidding applications, but the resin can be formulated with other Vitel copolyester resins to achieve the desired performance requirements for a variety of others as well.



TYPICAL PHYSICAL PROPERTIES

Description	Results
Appearance	Off-White Granules
CIELab Color	L* : 90 (min.) b* : 10 (max.)
Glass Transition (Tg)	-20°C
Softening Point	112°C
Intrinsic Viscosity	0.98 (dl/g)
Acid Number	0-2
Hydroxyl Number	1-3
Tensile Strength	1,060 psi
Elongation	1,600%
Specific Gravity	1.22
Molecular Weight (Mw)	96,000

V2200B

Vitel Copolyester Coating Resin

Key Features

- Excellent clarity, hardness, and abrasion resistance
- Good adhesion to a variety of substrates

V2200B is a hard, resinous, amorphous polymer exhibiting high tensile and low elongation. This premium quality resin finds specialized use either alone or modified in applications where high cohesive strength is of prime importance. It demonstrates superior adhesion, clarity, hardness and abrasion resistance. V2200B also exhibits good dielectric properties and good retention of physical properties after UV light exposure. Major applications for V2200B include being used as a primer, a binder for pigments in inks and as a lacquer for hard top coatings.



TYPICAL PHYSICAL PROPERTIES

Description	Results
Appearance	Clear to Golden Granules
Odor / Taste	None / None
Intrinsic Viscosity	0.59 dL/g
CIELab Color	L* : 95 (min.) b* : 10 (max.)
Solubility (25% in MEK)	100%
Specific Gravity	1.27

Selecting the Right Polyester Vitel Resin

Extrudable Film

Protective Coating

Laminating

Seal Strength

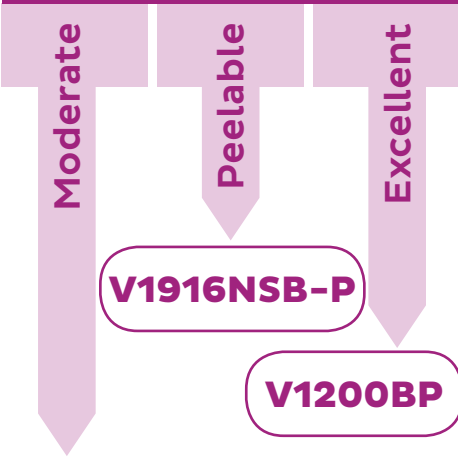

Heat Resistance

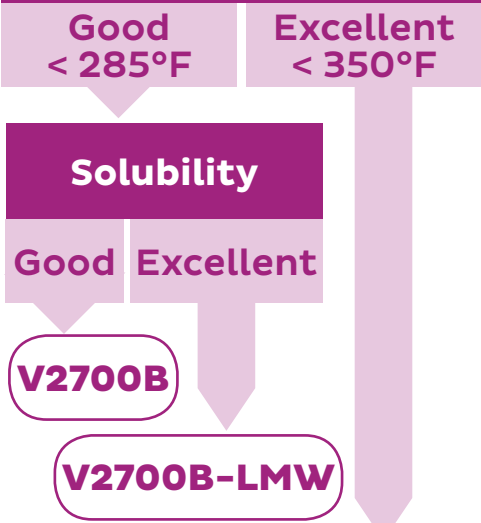

Activation Temperature



Activation Temperature

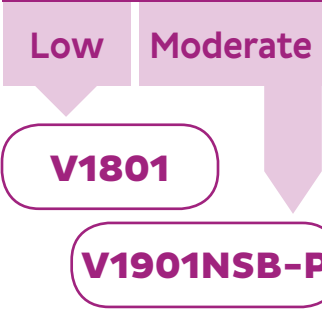

Solubility



Flexibility



Chemical Resistance

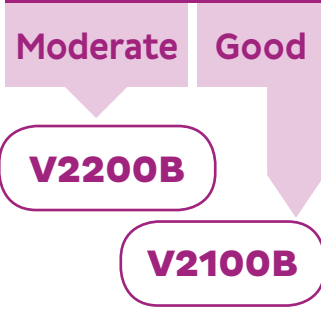

Chemical Resistance

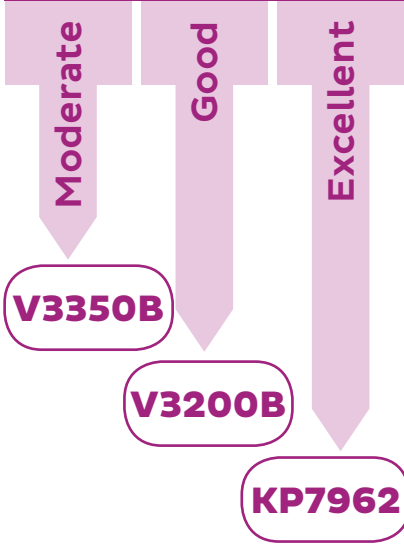

Vitel Resin Products

Product	Form	Morphology	B&R Softening Point (°C)	DSC Tg (°C)	Intrinsic Viscosity (dl/g)	Tensile (psi)	Elongation (%)	Recommended Activation Temperature (°C)	Product Benefits	
Extrusion Resins	V1200BP	Pellets	A	150	70	0.59	11,000	8	210	Very strong adhesive & cohesive strength, adhesion to a wide range of substrates
	V1801	Granules	SC	-	-25	1	-	-	110	Very low activation temperature & adhesion at low temperatures, excellent modifier to target adhesion levels
	V1901NSB-P	Pellets	SC	143	-4	0.92	800	60	143	Excellent modifier to target adhesion levels
	V1916NSB-P	Pellets	SC	145	0	0.84	-	-	160	Excellent peelable sealing properties
Coating Resins	V2100B	Pellets	A	150	66	0.59	-	-	150	Good chemical resistance, excellent temperature resistance
	V2200B	Pellets	A	156	69	0.59	9,600	7	156	Excellent temperature resistance, good solubility in a variety of solvents
	V2700B	Pellets	A	142	47	0.74	6,500	3	142	Lower activation temperature, good solubility in a variety of solvents
	V2700B-LMW	Pellets	A	115	50	0.58	-	-	120	Very low activation temperature, excellent solubility in a variety of solvents, higher hydroxyl functionality than V2700B
Laminating Resins	V3200B	Slab	A	129	15	0.78	400	800	129	Higher chemical resistance than V3300B & 3350B, good flexibility & adhesion
	V3300B	Slab	A	125	16	0.8	500	800	125	Good flexibility & adhesion
	V3350B	Slab	A	125	16	0.8	-	-	125	Improved color versus V3300B, good flexibility & adhesion
	V3550B-1	Slab	A	99	-11	0.85	30	2000	99	Highly flexible, good adhesion at low temperatures, very low melting temperature
	V7400NSN	Granules	SC	100	7	0.75	-	-	125	Soft & flexible, easily reacted with isocyanate curatives, tin-free
	KP7915	Granules	SC	100	-15	0.72	370	>1000	100	Excellent all-purpose product, very low melting temperature & good adhesion at low temperatures, good solubility in a variety of solvents
	KP7962	Granules	SC	100	-5	0.77	2,500	700	120	Excellent chemical resistance, high durability, improved color versus V7400NSN
Modifying Resin	V5833B	Powder	A	99	48	0.17	-	-	99	Excellent reactivity with isocyanate curatives, excellent solubility, improves substrate wetting & coating at higher solids content





POLYOLEFIN ADHESIVES

Coming Soon



POLYOLEFIN ADHESIVES

Coming Soon

POLYURETHANE ADHESIVES

Automotive Interior and Component Assembly | General Assembly
Filter Assembly | Flooring | Rigid Panel Bonding Textile
Bonding | Window and Door Assembly | Wood Bonding



Hot Melt Polyurethane Adhesives

Bostik's hot melt polyurethane adhesives are **solvent-free, moisture-curing adhesives**. The properties of the Supergrip® product line make these adhesives **a versatile option for demanding applications** in the transportation and assembly markets as well as several others.

What are Hot Melt Polyurethane Adhesives?

Polyurethane adhesives can be one or two-component systems. Bostik's Supergrip hot melt polyurethane adhesives are one-component adhesives, which do not require a secondary curative. While solid at room temperature, these adhesives liquefy when heated for application via bead, spray or

roll coat methods. Hot melt polyurethane adhesives react with atmospheric moisture to form thermoset materials, which yield characteristically strong and temperature-resistant bonds. Bostik's Supergrip products offer a variety of properties to meet the unique requirements of individual applications.





Choosing the Right Hot Melt Polyurethane Adhesive

Determine the preferred application method

Bostik's Supergrip adhesives span a range of viscosities providing flexibility in the choice of processing method.

- Low viscosity products can be swirl sprayed.
- High viscosity products allow for bead application.
- All are suitable for roll coating.
- Some products can be applied by all three methods.

Consider process requirements

While the recommended application temperature for Bostik's hot melt polyurethane adhesives is generally the same, between 110°-120°C, other process parameters can also guide the selection of the right Supergrip product:

- Manufacturing lines with high throughput might require high green strength.
- Other processes might require an extended handling window to position parts before the adhesive is set.

Hot melt polyurethanes can be designed to meet the unique requirements of each application, and Bostik's Supergrip products cover a range of processing considerations.

Align with performance requirements

Substrate adhesion is a primary concern. Some of Bostik's hot melt polyurethane products are better suited than others at adhering to low energy substrates. For example:

- Cured polyurethane adhesives typically offer good chemical, solvent and water resistance. Bostik's Supergrip product line offers varied levels of resistance to these conditions.
- Polyurethane adhesives can yield rigid bonds or bonds with more elastic properties; the Supergrip line offers products on both ends of the spectrum.



Benefits of Hot Melt Polyurethane Adhesives

Bostik's Supergrip adhesives offer a range of benefits:



Featured Hot Melt Polyurethane Adhesives

SG1578-164 Moisture Curing Hot Melt Polyurethane Adhesive

- Key Features**
- Excellent green strength and quick tack
 - Excellent creep resistance
 - Long open time

SG1578-164 is an all-purpose product that offers properties well-suited for assembly applications in a variety of markets. This product provides high initial tack, rapid development of strength upon application from the molten state and excellent creep resistance prior to curing. The physical properties of this adhesive make it suitable for use in a variety of manufacturing processes. SG1578-164 also offers excellent chemical and water resistance and exhibits good adhesion to a variety of substrates, including flexible vinyl, wood, ABS, fiberboard, HPL, steel, polyurethane foam and most plastics.



TYPICAL PHYSICAL PROPERTIES

Description	Results
Color	Off-White
Solids	100%
Thermoset Viscosity	15,000 cP @ 120°C
Density	9.6 lbs/gal (1.15 g/cm ³)
Green Strength (3 min., ambient conditions)	60 psi (410 kN/m ²)
Open Time	5 - 9 min. for a 10 mil film at ambient conditions
Application Temperature	110°C - 120°C

SG9621

Moisture Curing Hot Melt Polyurethane Adhesive

Key Features

- Good green strength
- Low application temperature
- Quick setting

SG9621 offers a good balance of strength and elasticity for robust applications. The quick setting characteristic of this product allows for fast processing of bonded components, and the chemical and water resistance of the cured adhesive provides an enduring bond. This product also has excellent adhesion to wood, steel, and a variety of plastics.



TYPICAL PHYSICAL PROPERTIES

Description	Results
Color	Opaque, Off-White
Solids	100%
Thermoset Viscosity	42,500 cP @ 100°C
Density	9.6 lbs/gal (1.15 g/cm ³)
Open Time	2 min. for a 10 mil film at ambient conditions
Application Temperature	110°C – 120°C

SGH0005-03A

Moisture Curing Hot Melt Polyurethane Adhesive

Key Features

- Aggressive bonds to a variety of substrates
- Good green strength and quick tack for fixturing assemblies
- Good heat resistance

SGH0005-03A offers a good balance of strength and elasticity for specialty applications. This adhesive is sprayable and processes cleanly. Its quick-setting characteristic allows for fast processing of bonded components, while the long open time offers an extended window to ensure proper positioning before the bond is set. A cured bond of SGH0005-03A provides good water resistance and excellent chemical resistance, extending the range of applications where it can be used. This product also has excellent adhesion to wood, steel and a variety of plastics.



TYPICAL PHYSICAL PROPERTIES

Description	Results
Color	Opaque, Off-White
Total Solids	100%
Viscosity	7,000 cP @ 120°C
Density	9.2 lbs/gal (1.10 g/cm ³)
Open Time	4 – 7 min. for a 10 mil film at ambient conditions
Application Temperature	110°C – 120°C

Selecting the Right Hot Melt Polyurethane Adhesive

Roll Coat Application

Swirl Spray Application

Handling Window (Open Time)

Short
<1 Minutes

Moderate
1-5 Minutes

Handling Window (Open Time)

Long
5-10 Minutes

Extended
>10 Minutes

Processing Speed (Green Strength)

Good

Excellent

Processing Speed (Green Strength)

Good

Excellent

Processing Speed (Green Strength)

Good

Excellent

SG9707*

SG9621*

SG1582-166*

SG1582-196*

Bond Elasticity

Excellent

Good

SGH0005-03A+

SG1582-082+

SG1578-164*+

SG97120P+



* Can also be bead applied
+ Can also be roll coated

Hot Melt Polyurethane Adhesive Products

Product	Appearance	Viscosity (cp)	Roll Coat	Bead Applied	Swirl Spray	Open Time (min) at ambient conditions, 10 mil film	Tensile at Break (psi)†	Elongation at Break (%)†	SAFT Heat Resistance on porous & non-porous substrates (°C)†	Application Temperature (°C)	Product Benefits
SG1578-164	Off-White Solid	15,000 @ 120°C	●	●	●	5 to 9	1050	830	193	110-120	Excellent green strength & quick tack, excellent creep resistance before cure, sprayable
SG1582-082	Off-White Solid	6,500 @ 120°C	●		●	>10	1500	860	206	110-120	Good green strength & aggressive tack, excellent chemical & water resistance, high heat resistance
SG1582-166	Off-White Solid	30,000 @ 120°C	●	●		<1	1750	1050	192	110-120	Excellent green strength & quick tack, excellent creep resistance before cure, short open time
SG1582-196	Off-White Solid	30,000 @ 120°C	●	●		1 to 3	570	1100	173	110-120	Very good low temperature flexibility, excellent green strength & quick tack, excellent creep resistance before cure
SG1827-160	Off-White Solid	15,000 @ 120°C	●	●	●	5 to 9	1050	830	193	110-120	Excellent green strength & quick tack, excellent creep resistance before cure, optical brightener for easy visualization
SG9621	Opaque, Off-White Solid	42,500 @ 100°C	●	●		2	3200	1550	185	110-120	Quick setting, good green strength, good chemical & water resistance, low application temperature
SG9707	Opaque, Off-White Solid	32,000 @ 100°C	●	●		<1	1250	1250	195	110-120	Quick setting, high cohesive strength, low application temperature
SG9712OP	Clear Solid	18,000 @ 100°C	●	●	●	10	350	350	180	110-120	Very long open time, strong initial tack & green strength, low application temperature, optical brightener
SGH0005-03A	Opaque, Off-White Solid	7,000 @ 120°C	●		●	4 to 7	1400	1400	195	110-120	Long open time, good green strength & quick tack, high bond elasticity
SGPURGE	Blue Pellets	27,000 @ 120°C				N/A	N/A	N/A	N/A	110-140	Neutralizes reactive polyurethane adhesives, good solvency to break down partially cured adhesive, pigmented

† cured at 25°C for 7 days, 50% relative humidity)



SILANE MODIFIED POLYMER SEALANTS

Coming Soon



SILANE MODIFIED POLYMER SEALANTS

Coming Soon





SOLVENT-BASED ADHESIVES

Coming Soon



SOLVENT-BASED ADHESIVES

Coming Soon

STYRENIC BLOCK COPOLYMER HOT MELT ADHESIVES

Labels | Tapes | Product Assembly | Foamable Gaskets
In-line Labeling | Auto Interior Bonding | Appliance Sealing
Pest Control Traps | Reseal Packaging | Credit Card Mailers



Hot Melt Styrenic Block Copolymer Adhesives

Bostik's range of hot melts based on styrenic block copolymers (SBC) offer **excellent hot tack** and **permanent pressure sensitivity**. These **thermoplastic** adhesives melt when heat is applied and quickly set forming **versatile** bonds in a variety of applications.

What are Hot Melt Styrenic Block Copolymer Adhesives?

Bostik's styrenic block copolymer (SBC) products are 100% solid, thermoplastic adhesives that are solid at room temperature, liquefy upon heating and re-solidify upon cooling. Hot Melt SBCs are based on polymers with hard and soft blocks that enable flexibility and strength when solidified while retaining the ability to re-melt. These adhesives can form nearly instantaneous bonds due to their fast set up and excellent hot tack. They are unique in the fact that they remain permanently pressure sensitive enabling

extended open times and ability to self-adhere even when solid.

Bostik's two categories of SBCs are: Pressure Sensitive Hot Melts and Hot Applied Hot Melts. The nature of these two types of adhesives are similar, but pressure sensitives are dialed in to have the right level of tack to enable bonds to be formed via pressure only. Hot applied adhesives are designed to offer strong bonds in the assembly of two substrates with a molten adhesive.

Pressure Sensitive HMSBC Adhesives

- For self-adhesive labels and tapes
- Broad range of pressure sensitivity levels including removable and permanent
- Can be applied via slot-die or roll-coater
- Available in solid drums and hand feed chubs

Hot Applied SBC Adhesives

- Can be applied via slot-die, bead application and spray coaters
- Available in solid drums and hand feed chubs
- Broad range of characteristics including low temperature flexibility, high heat resistance or foamability



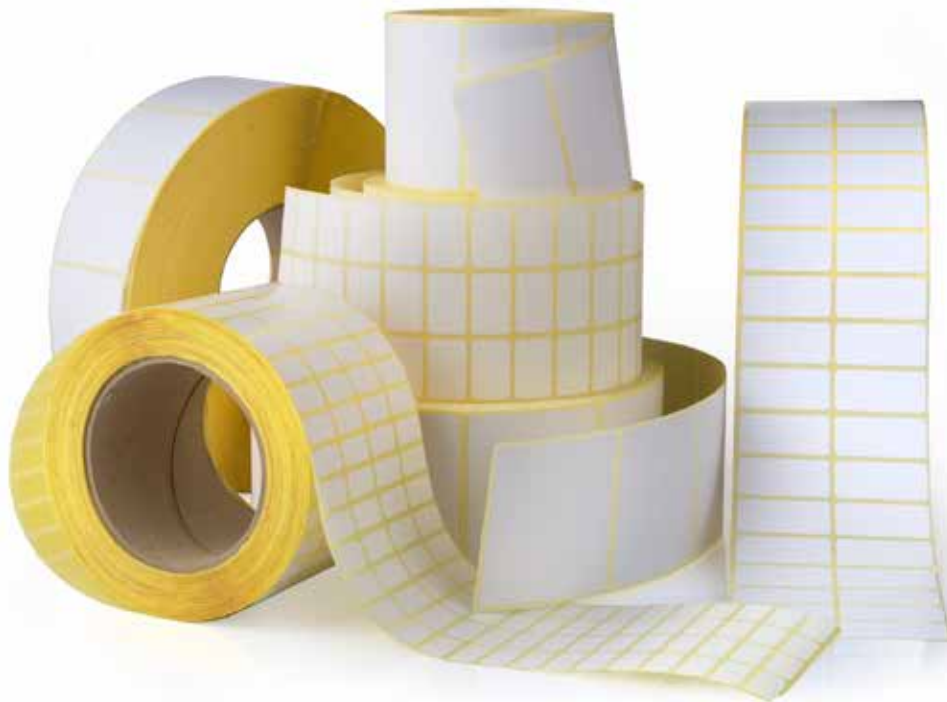

Choosing the Right Hot Melt SBC Adhesive

Determine the end use requirements

Hot melt SBCs are used for a variety of applications whether you need:

- Dialed-in pressure sensitivity for aggressive grab or clean removal
- Optimized viscosity for fast line speeds
- A foamable adhesive to create a custom gasket like bead
- High heat resistance for demanding environments

Choose an optimal pressure sensitivity

- In pressure sensitivity driven applications, like self-adhesive labels, the minimum application temperature, loop tack and 180° peel ensure the correct level of pressure sensitivity is selected.
- In most hot applied applications, pressure sensitivity is a secondary selection criteria. These products are usually selected first based on substrate compatibility, viscosity and heat resistance.

Understand the required heat resistance

- Thermoplastic adhesives cannot be subjected to applications where elevated temperatures might reactivate the adhesive. Typical softening points of hot melt SBCs range from 150° to 300°F.
- Shear Adhesive Failure Temperature (SAFT) gives an indication of the adhesive's ability to hold a bond at elevated temperature. Typical SAFT of hot melt SBCs range from 125°F to over 275°F.

Select an appropriate viscosity

- Viscosity can affect application temperature of the adhesive and degree of wet out on a substrate.
- Viscosity will affect what application methods are appropriate; be it extrusion, spray, roll coat or other methods.

Consider the adhesive form

- For high throughput applications with accessibility to a hot drum unloader, use drums ranging in fill level from 350 - 475lbs.
- For smaller scale applications with a small melt tank, use the convenient, hand-feed, package-less package form, fill and seal and small pillow coextrusion forms.

Benefits of Pressure Sensitive Hot Melt SBC Adhesives

Bostik's pressure sensitive hot melt SBC adhesives offer a range of benefits:

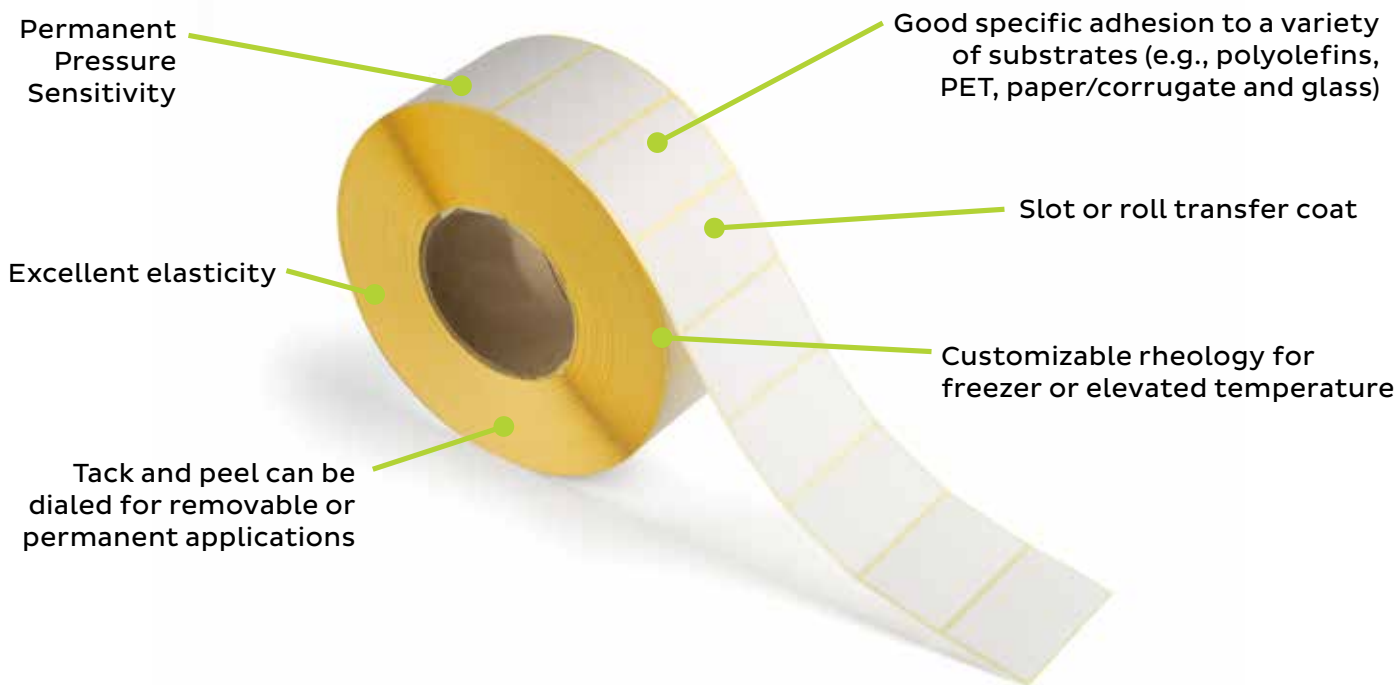

Featured Pressure Sensitive Hot Melt SBC Adhesives

H2211 High Temperature Resistant Tape & Assembly Adhesive

Key Features

- Excellent heat resistance
- High tack and peel
- Strong bonds to plastics and paperboard

H2211 is a pressure sensitive hot melt SBC adhesive for adhering trim and sound deadener materials to various plastics and metals. H2211 has high tack and high shear, which is why it is excellent for durable labels, tapes and product assembly applications.



TYPICAL PHYSICAL PROPERTIES

Description	Results
Thermoset Viscosity (Brookfield - ASTM D3236)	25,950 cP @ 325°F (163°C) 12,000 cP @ 350°F (177°C) 8,300 cP @ 375°F (191°C)
Softening Point (Herzog ASTM E28)	250°F (121°C)
Suggested Running Temperature	325 - 375°F (163-191°C)
Density	0.94 g/cc @ 77°F (25°C)

H20192

General Purpose Label Adhesive

Key Features

- Excellent balance of tack and peel
- Good adhesion to corrugate
- Balanced low temperature performance

H20192 is a pressure sensitive hot melt SBC adhesive for labeling applications. H20192 has a great balance of tack and peel on various substrates used for shipping. This low viscosity product also has excellent specific adhesion to poly and corrugate and is sold in drums.



TYPICAL PHYSICAL PROPERTIES

Description	Results
Thermosel Viscosity (Brookfield - ASTM D3236)	13,675 cP @ 300°F (149°C) 8,663 cP @ 325°F (163°C) 5,850 cP @ 350°F (177°C) 3,995 cP @ 375°F (191°C)
Softening Point (Herzog ASTM E28)	184°F (84°C)
Suggested Running Temperature	300-350°F (149-177°C)
Density	0.98 g/cc @ 77°F (25°C)

H2259-01

Freezer Grade Label Adhesive

Key Features

- Excellent cold temperature performance
- Excellent adhesion to polyolefin
- Very good process-ability

H2259-01 is light in color and has low viscosity with good die-cuttability. It also has excellent bonding to polyolefin substrates and paper with application temperatures down to -15°F. H2259-01 is used for freezer grade labels and tapes used on common packaging substrates for freezer conditions such as frozen meats, ice cream containers and cryogenic labeling applications.



TYPICAL PHYSICAL PROPERTIES

Description	Results
Thermosel Viscosity (Brookfield - ASTM D3236)	14,700cP @ 325°F (163°C) 8,300 cP @ 350°F (177°C) 5,200 cP @ 375°F (191°C)
Softening Point (Herzog ASTM E28)	206°F (97°C)
Suggested Running Temperature	325-375°F (163-191°C)
Density	0.94 g/cc @ 77°F (25°C)

Selecting the Right Pressure Sensitive Hot Melt SBC Adhesive

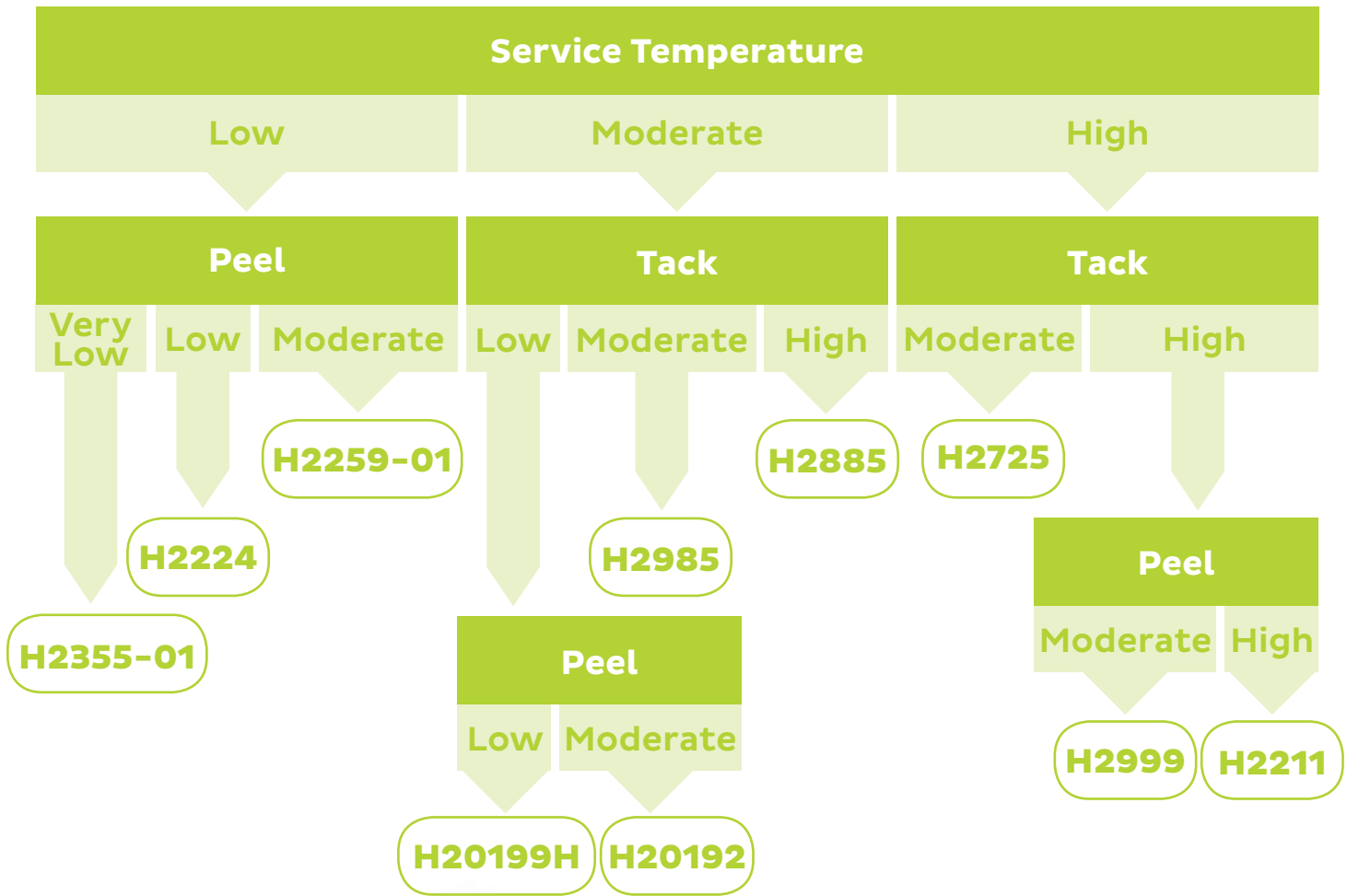

Pressure Sensitive Hot Melt SBC Products

Product	Minimum Application Temperature (°F)	Loop Tack	180 Peel	SAFT (°F)	Viscosity (cP)		Softening Point	Suggested Running Temp (°F)	Density @ 77°F	Comments
H2355-01	-33.4	1.4	0.6	144	11,700 @ 300°F	8,000 @ 325°F	199	310-340	0.95	Hot melt SBC for removable labels with consistent low peel bond, residue-free removal and low temperature adhesion
H2259-01	-8.2	5.2	2.6	137	14,700 @ 325°F	8,300 @ 350°F	206	325-375	0.94	Hot melt SBC for freezer grade labels, excellent die-cutability, strong bond to packaging containers and films in the presence of moisture, can be applied at room or freezer temperatures
H4382H	6.2	3.7	2.2	158	16,500 @ 325°F	11,000 @ 350°F	219	310-360	1.10	Hot melt SBC for direct food contact labels, bonds well to a variety of fruit and vegetable surfaces, residue-free removal, wide application temperature range, FDA 175.125(b) approved
H2224	6.2	4.4	4.8	137	9,100 @ 325°F	5,750 @ 350°F	200	325-355	0.94	Hot melt SBC for dairy labels, strong adhesion to HDPE containers & PP caps, adhesion at refrigeration temperature, bonds in the presence of moisture
H2548B	13.4	6.0	4.7	142	8,500 @ 300°F	5,500 @ 325°F	196	275-350	0.96	Hot melt SBC for tire labels, bonds well to winter, summer, shaved and unshaved tires, resistant to low molecular weight components
H20129	18.8	4.3	3.8	148	15,300 @ 350°F	11,000 @ 375°F	183	350-375	0.94	Hot melt SBC for no-label look labels, works with or without a primer, excellent wet out, good diecutability, repositionable, does not distort film
H20199H	24.2	2.6	1.8	156	15,100 @ 325°F	10,075 @ 350°F	196	300-375	1.20	Hot melt SBC for general purpose labels, balanced tack & peel, excellent converting, good adhesion to polyolefin substrates
H2345H	18.8	5.2	5.1	140	14,512 @ 325°F	9,625 @ 350°F	184	315-365	1.10	Hot melt SBC for packing slip & shipping labels, balanced peel and tack, excellent converting, bonds well to common shipping substrates, wide range of application and service temperatures
H20192	21	3.8	6.2	128	8,663 @ 325°F	5,850 @ 350°F	184	300-350	0.98	Hot melt SBC for general purpose labels, balanced tack & peel, bonds well to difficult shipping substrates, excellent converting, good low temperature performance
H2985	29.6	6.0	5.5	141	10,000 @ 325°F	13,825 @ 350°F	175	325-375	0.98	Hot melt SBC for general purpose labels, high tack, bonds well to difficult shipping substrates
H2885	44	11.3	7.2	157	13,600 @ 325°F	7,850 @ 350°F	222	325-350	0.94	Hot melt SBC for general purpose labels, high tack & peel, excellent converting, bonds well to a wide range of substrates
H2571-01	31.4	10.0	7.5	168	15,100 @ 325°F	8,100 @ 350°F	224	290-340	0.94	Hot melt SBC for high performing labels, good bond to corrugate at room temperature, excellent diecutability, high release, high tack & peel
H2725	20.6	5.0	4.5	186	12,600 @ 350°F	10,125 @ 375°F	233	325-375	0.95	Hot melt SBC for dry wall seam tape, wide range of temperature performance & temperature resistance
H2211	45.8	10.5	8.2	195	12,000 @ 350°F	8,300 @ 375°F	250	325-375	1.02	Hot melt SBC for durable labels, tapes & product assembly. High shear, high tack, excellent adhesion to a variety of substrates
H20060	22.4	5.0	4.5	205	15,000 @ 325°F	9,000 @ 350°F	238	300-375	0.95	Hot melt SBC for removable road marking tape, good bond to cold & moist road surfaces, residue-free removal
H2999	33.2	8.9	4.8	197	17,000 @ 350°F	7,500 @ 375°F	278	325-375	0.98	Hot melt SBC for high temperature tape & water shield applications, high temperature resistance, high shear, high tack
H20021PB	--	--	--	--	1,050 @ 250°F	--	--	275 - 300	0.94	Hot melt SBC for tray-type rodent traps, peanut butter scented

Benefits of Hot Applied Hot Melt SBC Adhesives

Bostik's hot applied hot melt SBC adhesives offer a range of benefits:

Can be applied via slot die, bead application and spray coaters

High viscosity enabling use on porous textile-like substrates

Excellent elasticity

Foamable

Fast set with extended open times



Good specific adhesion to a variety of substrates (e.g., polyolefins, PET, paper/corrugate and glass)

Customizable rheology for cold or hot, structural or flexible applications

Featured Hot Applied Hot Melt SBC Adhesives

H5265 Resealable Adhesive

- Key Features**
- High tack
 - Low peel
 - Resealable

H5265 is a hot applied hot melt SBC adhesive with high tack and peel and resealability. This product is commonly used on plastic bags or pouches that need to be resealable.



TYPICAL PHYSICAL PROPERTIES	
Description	Results
Thermosel Viscosity (Brookfield - ASTM D3236)	2,235 cP @ 300°F 1,330 cP @ 325°F 850 cP @ 350°F
Softening Point (Ring and Ball Herzog - ASTM E28)	172°F
Suggested Running Temperature	300 - 350°F
Density	0.95 g/cc @ 77°F

H2790

Bottle Labeling Adhesive

Key Features

- Strong adhesion in hot and cold environments
- Good machining
- Colorless pressure sensitive

H2790 is a hot applied hot melt SBC adhesive. It is a colorless, pressure sensitive labeling adhesive that machines well on rotary labelers. H2790 also offers strong adhesion in both hot and cold end use environments, providing versatility in applications.



TYPICAL PHYSICAL PROPERTIES

Description	Results
Thermosel Viscosity (Brookfield - ASTM D3236)	2,250 cP @ 250°F 1,200 cP @ 275°F 750 cP @ 300°F
Softening Point (Ring and Ball Herzog ASTM E28)	155°F
Suggested Running Temperature	275-350°F
Density	0.97 g/cc @ 77°F

H2315-02

High Performance General Assembly Adhesive

Key Features

- High heat resistance
- Balanced tack and peel
- Foamable

H2315-02 is a work horse, hot applied hot melt SBC adhesive that exhibits excellent heat resistance and can withstand high shear forces without compromising tack and peel. It has found exceptional utility in direct-applied automotive watershield attachments and loadfloor hardboard bonding; however, its versatility lends itself to a variety of demanding product assembly applications.



TYPICAL PHYSICAL PROPERTIES

Description	Results
Thermosel Viscosity (Brookfield - ASTM D3236)	29,000 cP @ 325°F (162.8°C) 13,500 cP @ 350°F (176.7°C) 8,550 cP @ 375°F (190.6°C) 4,850 cP @ 400°F (204.4°C)
Softening Point (Herzog ASTM E28)	248°F (120°C)
Suggested Running Temperature	350-390°F (176.7-198.9°C)
Density	0.94 g/cc @ 77°F (25°C)

Selecting the Right Hot Applied Hot Melt SBC Adhesives

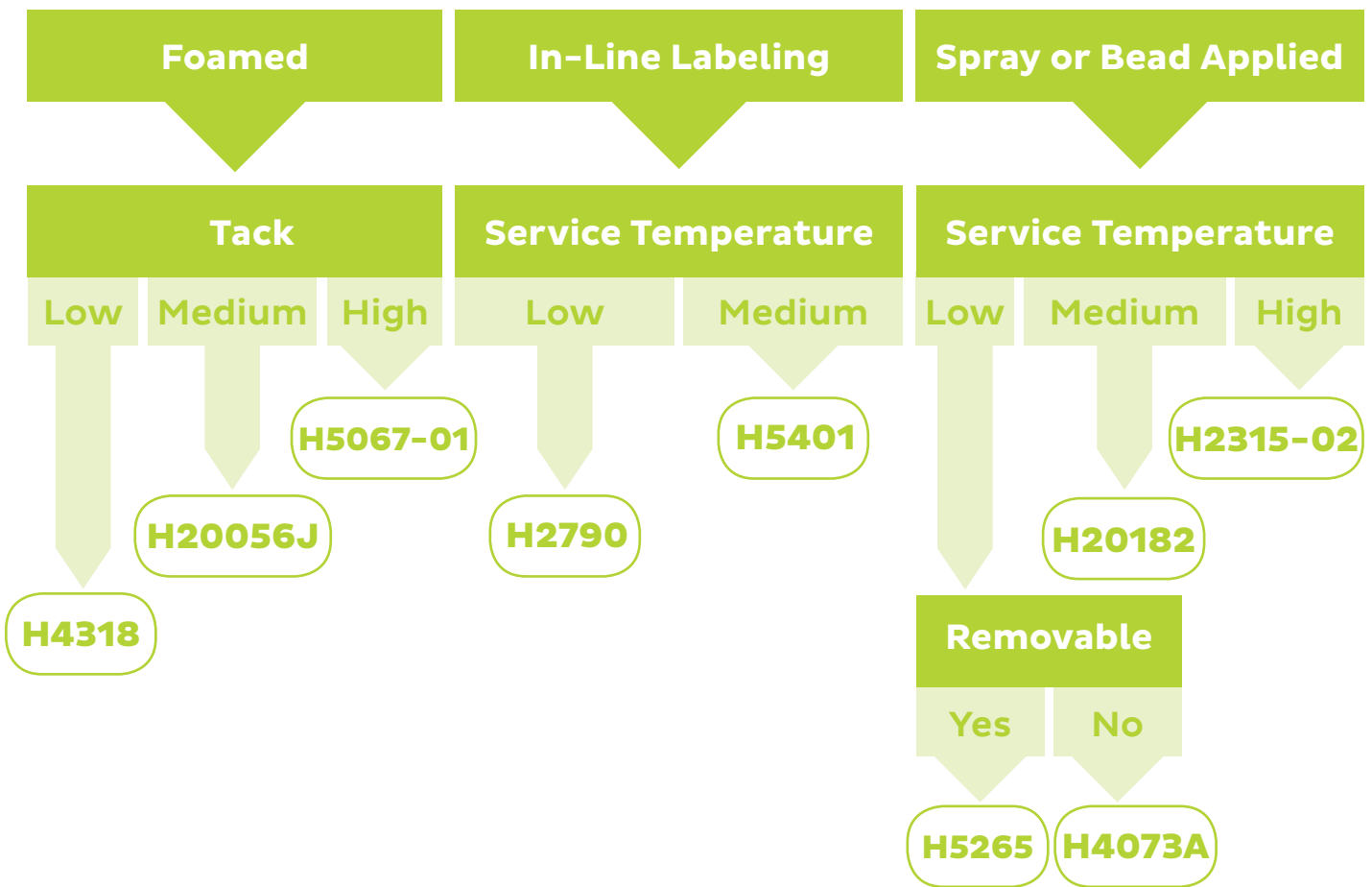

Hot Applied Hot Melt SBC Adhesives Substrate Guide

Product		Substrate Compatibility							
		PP/PE	PET	Paper/ Corrugate	Metals	Glass	Textiles	Wood	Urethane Foam
Assembly	H20080	●	○	○	○		●	○	
	H2900	●	○	○	○		●	○	
	H2345	●	●	●	○	●	○	○	
	H4073A	●	○	○	○		●	○	
	H2465	●	○	○	○		●	○	
	H20182	○	○	○	○	●	●	○	
	H2284-01	●	●	●	○	●	●	○	
	H2187-01	●	●	●	○	●	●	○	○
	H2211	●	●	●	●	○	●	○	○
	H2315-02	●	●	●	●	○	●	○	○
	H2038	○	●	○	○		●		
	H2665	○	●	○	○		○		
Labeling	H2790	●	●	●					
	H5401	●	●	●	○				
	H4360	●	●	●	○	●			
Removable	H5434			●		●			
	H998-337	●	●	●	○				
	H5077	●	●	●					
	H995-373	●	●						
	H5265	●	●	●					

● Excellent ○ Good

This chart above provides typical substrates with which Bostik's HMPA adhesives have been used, but is not a guarantee of suitability. Bostik recommends evaluating the performance of a HMPA adhesive in individual applications to ensure performance requirements are achieved.

Hot Applied Hot Melt SBC Adhesives Products

Product	Form	Foamable	Heat Resistance	Residual Tack	Viscosity (cp)		Softening Point		SAFT (°F)	180° Peel to SS (lbs/in ²)	Suggested Running Temp (°F)	Comments
H20080	Drums & Hand		Low	High	2,100 @ 300°F	1,200 @ 325°F	175	125	6.3	250 - 338		Light color & low odor light assembly hot melt SBC
H2900	Hand		Low	Medium	4,200 @ 300°F	2,400 @ 325°F	210	133	6.3	275 - 325		Low viscosity general assembly hot melt SBC
H4073A	Hand		Low	Medium	2,800 @ 300°F	1,500 @ 325°F	172	149	6.7	275 - 325		Light color & low odor general assembly hot melt SBC
H2465	Drums & Hand		Medium	High	3,800 @ 300°F	2,370 @ 325°F	191	153	--	250 - 300		Low viscosity general assembly hot melt SBC with high tack
H20182	Hand		Medium	Medium	4,750 @ 300°F	3,000 @ 325°F	192	157	4.5	275 - 350		Balanced low & high temperature performance, general assembly hot melt SBC
H2187-01	Drums & Hand		Medium	High	23,400 @ 300°F	15,100 @ 325°F	224	168	7.4	290 - 340		Medium heat resistance high performance assembly & tape hot melt SBC with high tack
H2211	Drums & Hand	●	High	High	12,000 @ 350°F	8,300 @ 375°F	250	195	8.2	325 - 375		High shear, high performance assembly & tape hot melt SBC with high tack
H2315-02	Drums & Hand	●	High	Medium	13,500 @ 350°F	8,550 @ 375°F	248	206	5.7	350 - 390		High shear, high heat resistance, high performance assembly hot melt SBC
H2038	Hand		High	Low	54,700 @ 350°F	22,700 @ 375°F	275	225	8	390 - 400		High shear, high viscosity, high heat resistance, high performance assembly hot melt SBC with low residual tack
H2665	Hand		Very High	Medium	32,500 @ 350°F	8,500 @ 375°F	290	240	7.3	375		High shear, extreme heat resistance high performance assembly & tape hot melt SBC
H4318	Drums & Hand	●	Medium	Low	4,000 @ 275°F	1,000 @ 300°F	201	--	--	240 - 270		FIP, general purpose cabinet seal hot melt SBC
H5067-01	Drums & Hand	●	Medium	High	11,500 @ 350°F	8,000 @ 375°F	215	--	--	350 - 375		FIP, general purpose weatherstrip attachment hot melt SBC
H20056J	Drums & Hand	●	High	Medium	22,250 @ 350°F	5,000 @ 375°F	295	--	--	325-375		FIP, High shear watershield hot melt SBC, gray in color
H2999	Drums & Hand	●	High	High	17,000 @ 350°F	7,500 @ 375°F	278	--	--	325 - 375		FIP, High heat resistant watershield & tape hot melt SBC
H5141K01	Drums & Hand	●	Very High	Low	29,600 @ 375°F	8,000 @ 400°F	330	--	--	375 - 400		FIP, High sag resistance gasket hot melt SBC, black in color
H2790	Drums & Hand		Low	Medium	1,200 @ 250°F	750 @ 300°F	155	--	--	290-310		Hot melt SBC for in-line bottle labeling, light color & odor, sprayable, excellent adhesion to difficult substrates
H5401	Drums & Hand		Medium	Medium	1,750 @ 250°F	800 @ 275°F	190	--	--	275-300		Hot melt SBC for in-line labeling, optimized for Nordson Patternjet® spray system, good heat resistance
H4360	Drums & Hand		Low	High	1,075 @ 275°F	688 @ 300°F	162	--	--	275-325		Hot melt SBC for non-carbonated in-line bottle labeling, clean machining, high tack, superior adhesion to glass & PET bottles
H5434	Drums		Low	Medium	5,650 @ 300°F	2,300 @ 325°F	215	--	--	300-350		Hot melt SBC for direct mail market applications, cohesive failuring adhesive to reduce fiber tear, very low staining, light color & odor
H998-337	Drums & Hand		Low	Low	9,050 @ 250°F	2,775 @ 275°F	196	--	--	225-350		Hot melt SBC used for strippable protective coating, edge & sanitary protection, low tack, very low color
H5265	Hand		Low	High	2,250 @ 300°F	1,330 @ 325°F	172	--	--	300-350		Hot melt SBC for pouch seal, high peel, high tack, used for resealable applications



WATER-BASED ADHESIVES

Coming Soon

WATER-BASED



WATER-BASED ADHESIVES

Coming Soon

WATER-BASED



Bostik
and adhesives



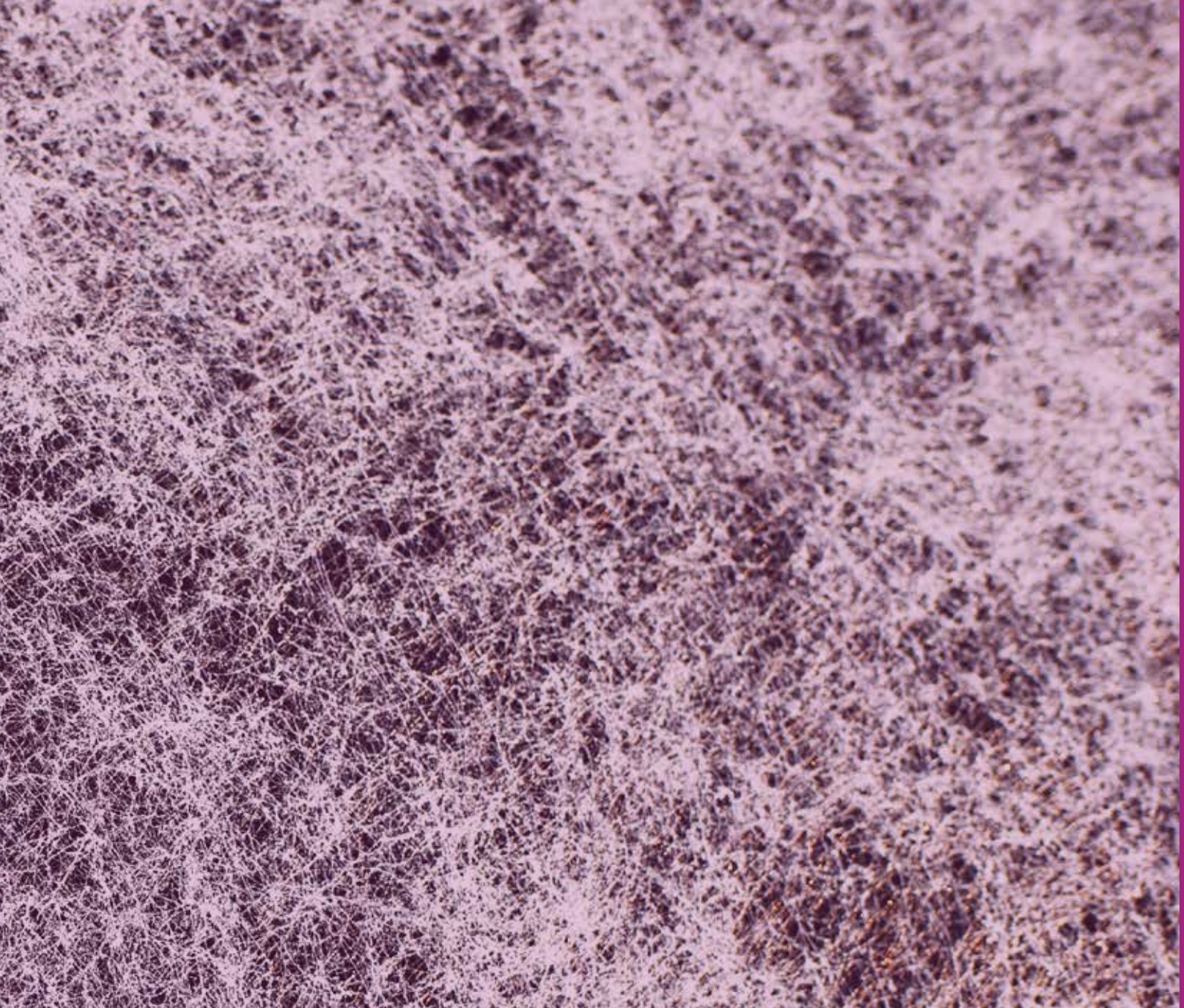

WEB ADHESIVES

**Automotive Interiors | Composite Manufacturing | Furniture
Panel Formation | Seating | Textile Bonding and Laminating**

Web Adhesives

Bostik offers a unique family of web adhesives that provides many **advantages for customers and simplifies the use of adhesives** in their manufacturing processes.

What are Web Adhesives?

Webs are hot melt adhesives that have been converted into a non-woven that handles like a fabric. Polyamide, polyester and polyurethane polymers are used to produce a variety of web products. They can be made by a modified melt blown process for the standard web adhesives or through a modified blown film process to make Sharnet® web products.

Though the two manufacturing processes share some similarities, each is complemented by the other's unique formulation and performance features. The complete product mix makes Bostik one of the market leaders in web adhesive technology.

Standard Web Adhesives



- Made in a fine filament pattern that offers good textile hand and uniform adhesive coverage
- Basis weights range from 15 to 100 grams per square yard
- Standard width is 60 inches; however, custom widths are available from 10 to 75 inches.

Sharnet Web Adhesives



- Produced through a foam fibrillation method that creates a coarser pattern web
- Basis weights range from 12 to 60 grams per square yard
- Standard width for these webs is 60 inches, with custom widths available from 10 to 75 inches
- Polymer blends combine the properties of two or more polymer types as well as the addition of additives to achieve desired web characteristics.





Choosing the Right Web Adhesive

Select the correct base polymer

- The base polymers (polyesters, polyamides and polyurethanes or blended alloys) used in Bostik's web adhesives offer unique benefits for performance, handling time and manufacturing throughput.
- Bond performance is impacted by the base chemistry of the web.

Consider the melting temperatures or softening point

- Typical activation temperatures range from 170°F to 330°F.
- Thermoplastic adhesives cannot be subjected to applications where elevated temperatures might reactivate the adhesive.
- The base polymer chemistry impacts the softening and melting temperatures, which affect processing conditions.

Consider viscosity, solvent and water resistance

- Viscosity can affect bond performance of some multi-layer, specialty laminates.
- Water and solvent resistance will vary, depending on the base chemistry of the web.

Choosing the right basis weight

- The adhesive pattern and permeability vary depending on the web manufacturing process.
- Uniformity will influence bond consistency and certain performance-related ratios, such as bond strength-to-porosity.
- Higher basis weight web adhesives reduce the permeability of the bond.
- Lower basis weight web adhesives could result in bond failure.
- Determining the ideal basis weight requires consideration of the substrates being bonded, base chemistry of the web as well as the activation temperature and other processing requirements.

Flame retardancy

- Bostik offers flame retardant Sharnet web adhesives for applications where flame retardancy is a performance requirement.
- Flame retardant Sharnet web adhesives are available in a variety of basis weights and chemistries to achieve the best bond performance.

Benefits of Web Adhesives

Bostik's web adhesives are thin, heat-activated, fabric-like materials that vary in basis weight and polymer chemistry. The flexibility and versatility of the web adhesives

accommodate manufacturers' growing interest in new substrates and offer several advantages over other bonding options.

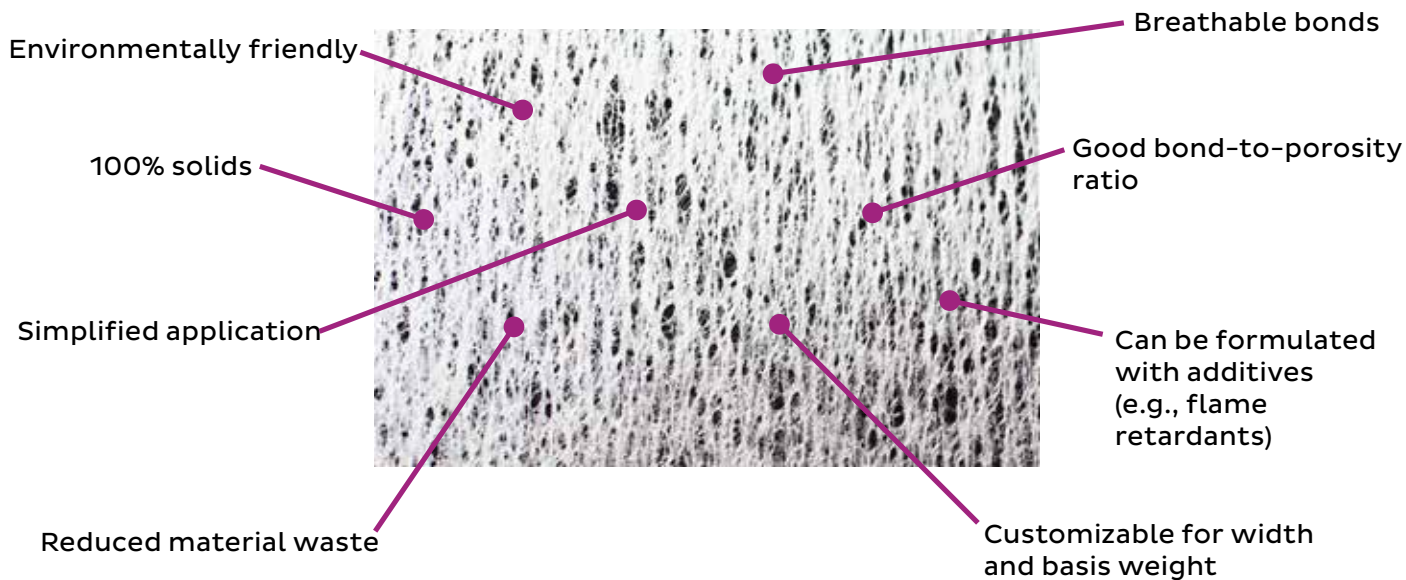

Featured Web Adhesives

SH4275FR-A

Flame Retardant Polyester Sharnet Web Adhesive

Key Features

- Moderate heat activation temperature
- Good flame retardancy
- Flexible adhesive bonding

SH4275FR-A is based upon a high-performance, polyester polymer that resists laundering and has good resistance to oils and plasticizers. The flame resistance of this product was designed for use in textile laminations where a flame retardant adhesive is required to assist other flame retardant substrates in producing a non-burning composite. SH4275FR-A bonds to a variety of textiles, urethane foams and plasticized vinyls.



TYPICAL PHYSICAL PROPERTIES

Description	Results
Appearance	Off White
Base	Polyester
Basis Weight Range	0.5-2.1 oz/yd ² (17-71 g/m ²)
Width	Up to 74 in (188 cm)
DSC Melt Point*	248°F (120°C)
Recommended Activation Temp	265-350°F (130-177°C)

* On base polymer

SPA145FR-A

Flame Retardant Polyamide Sharnet Web Adhesive

Key Features

- Manages adhesive usage versus liquids
- Excellent adhesion to a variety of substrates
- Superior flame retardancy

SPA145FR-A is based upon a high-performance, polyamide polymer that has good dry cleaning solvent resistance. The flame resistance of this product was designed for use in textile laminations where a flame retardant adhesive is required to assist other flame retardant substrates in producing a non-burning composite. SPA145FR-A bonds to a variety of textiles, urethane foams and plasticized vinyls.

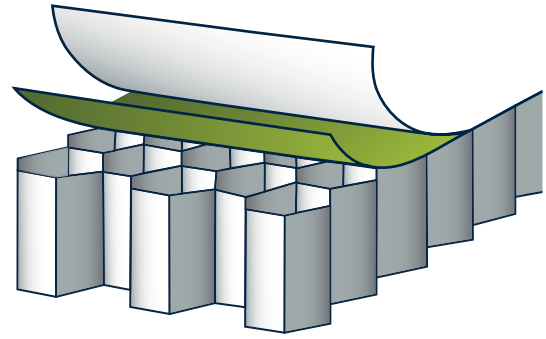

TYPICAL PHYSICAL PROPERTIES

Description	Results
Appearance	White to Off White
Base	Nylon Polyamide
Basis Weight Range	0.5-2.1 oz/yd ² (17-71 g/m ²)
Width	Up to 74 inches (188 cm)
SAFT Heat Resistance	284°F (140°C)
B&R Melt Point	289°F (143°C)
Min. Activation Temperature	302°F (150°C)
Recommended Activation Temp	320°F (160°C)

PE120

Polyester Web Adhesive

Key Features

- Moderate heat activation temperature
- Excellent adhesion to textiles and urethane foam
- Good temperature resistance

PE120 is a web adhesive based upon a high-performance, polyester polymer. The product resists repeated home launderings, bond to a wide variety of fabrics, foams and vinyls and has good resistance to oils and plasticizers.



TYPICAL PHYSICAL PROPERTIES

Description	Results
Appearance	Milky White
Base	Polyester
Basis Weight Range	15-100 g/yd ² (18-120g/m ²)
Width	Up to 75 in (190 cm)
DSC Melt Point*	248°F (120°C)
Density*	9.6 lbs/gal (1.15 g/cc)
Thermosel Viscosity*	125,000 cP @419°F (215°C)
Min. Activation Temperature	280°F (138°C)

* On Base Polymer

Selecting the Right Web Adhesive

Flame Retardant

Substrates

- Vinyls
- Urethanes
- Textiles or Fabrics
- Polyester Foams
- Leather
- Metal
- Wood

Green Grab

Standard

Excellent

SH4275FR-A

SPA145FR-A

Non-Flame Retardant

Substrates

- Vinyls
- Urethanes
- Textiles or Fabrics
- Polyester Foams
- Leather
- Metal
- Wood

Green Grab

Standard

Excellent

Heat Resistance

<170°F

<210°F

<250°F

<330°F

<220°F

<260°F

<285°F

PE75

PE103

PE120

PE165

PA145

SPA128

SPA110



Web Adhesive Substrate Guide

Product	Substrate Compatibility													
	Fabric	Leather	Urethane Foam	Wood	Metals	Aluminum	Fiberglass	Treated PP	PVC	ABS	PVDF	PEI	PEEK	Phenolic
PA115	●		●	●	●	●	●	●		●				●
PA145	●		●	●	●	●	●	●		●				●
PE75	●	●	●			●	●	●						●
PE85	●	●	●			●	●	●						●
PE103	●	●	●			●	●	●	●	●				●
PE120	●		●			●	●	●		●				●
PE165	●		●			●	●	●						●
PE170	●		●			●	●	●						●
SPA110	●	●	●	●	●	●	●	●	●	●				●
SPA111	●	●	●	●	●	●	●	●	●	●				●
SPA122	●	●	●	●	●	●	●	●	●	●				●
SPA128	●	●	●	●	●	●	●	●	●	●				●
SPE118V	●	●	●			●	●	●		●				●
SPU131	●	●	●	●	●	●	●	●	●	●				●
SH4275FR-A	●		●			●	●	●			●		●	●
SPA145FR-A	●	●	●	●	●	●	●	●	●	●	●	●	●	●

The chart above provides typical substrates with which Bostik's web adhesives have been used, but is not a guarantee of suitability. Bostik recommends evaluating the performance of a web adhesive in individual applications to ensure performance requirements are achieved.

Web Adhesive Products

Product	Base Polymer Type	Ball & Ring Melt Point (°C)		DSC Melt Point (°C)	Thermoset Viscosity (cp)	Minimum Dry Heat Activation Temperature (°C)	Elevated Temperature Resistance (°C)	Wash Resistance	Dry Clean Resistance	Product Benefits
Standard	PA115	Nylon polyamide	125	115	400,000 @ 180°C	115	115	Fair	Excellent	Steam activatable, general purpose
	PA145	Nylon polyamide	151	145	250,000 @ 180°C	141	140	Fair	Excellent	Steam activatable, high temperature resistance, good chemical resistance
	PE75	Polyester	90	82	160,000 @ 180°C	85	75	Good	Poor	Low melt temperature
	PE85	Polyester	100	90	150,000 @ 180°C	93	88	Excellent	Poor	Low melt temperature, good elongation
	PE103	Polyester	115	103	140,000 @ 180°C	105	100	Excellent	Poor	General purpose
	PE120	Polyester	131	120	125,000 @ 215°C	132	120	Excellent	Good	Good temperature resistance, general purpose
	PE165	Polyester	175	165	140,000 @ 215°C	180	165	Excellent	Excellent	High temperature resistance
	PE170	Polyester	170	170	145,000 @ 215°C	177	170	Excellent	Good	High temperature resistance
Sharnet	SPA110	Nylon polyamide	105	100	475,000 @ 180°C	105	105	Fair	Excellent	Excellent adhesion, low activation temperature
	SPA111	Nylon polyamide/EVA	125	110	340,000 @ 180°C	113	135	Good	Excellent	Higher heat resistance than SPA110
	SPA122	Nylon polyamide	128	113	350,000 @ 180°C	113	121	Good	Excellent	Versatile, general purpose
	SPA128	Nylon polyamide	N/A	115	1,375,000 @ 180°C	125	121	Good	Fair	Excellent green strength & adhesion, specialty adhesives for bonding to glass-filled polypropylene substrate
	SPE118V	Polyester	N/A	117	80,000 @ 215°C	112	110	Excellent	Good	General purpose
	SPU131	Polyurethane	N/A	143	-	149	150	Excellent	Excellent	Excellent chemical resistance, flexible, can be cross-linked
	SH4275FR-A	Polyester	N/A	120	409,000 @ 210°C	130	120	Excellent	Good	Flame retardant
	SPA145FR-A	Nylon polyamide	143	143	182,000 @ 210°C	150	140	Fair	Excellent	Flame retardant, steam activatable



**Smart help:
1-800-726-7845**

Bostik, Inc.

11320 W. Watertown Plank Road | Wauwatosa, WI | 53226 | USA

an Arkema company

www.bostik.com/us